

Battery Powered Photocell User Manual

Item No.: LM101

Thank you for purchasing the battery powered photocell (LM101). It can be easily installed because of its special power supply design for emitter, only use 2*AA dry battery. The photocell also integrates an Internal Rotation system that the angel of the beam can be adjusted from 0 to 180°. These advantages make the unit ideal for fixing to a moving leaf of gate or wherever it is difficult to get cabling to the emitter.

Specifications

Working Voltage: 12-24VAC/DC

Battery type :2*1.5V,AA Dry for emitter

Working Current: emitter: ≤65uA, receiver: ≤40mA

Sensing Range: ≥40 Feet (12 m)

Internal Rotation system adjusted angel: 0-180°

Working temperature: -20°C-60°C

Output Relay contact loading Capacity: 1A/30VDC

Protection Degree: IP54

Product Size: 128*50*32 mm

Wiring Connection

Diagram below is to describe the function of the output terminals, the jumpers and the other key components.

J2: Option for the frequency of the receiver and transmitter. Factory default setting is F1.

Notice: Emitter and receiver must be in the same frequency

J3: Option for output type of the photo, Normal Open or Normal Closed. Factory default setting is NC.

J4: Option for buzzer warning for beam broken & battery low voltage, enabled or disabled. Factory default setting is enabled.

BATT LOW Terminal : Connection for external low battery warning device.

Definition of the other terminals please refers to the below diagram.

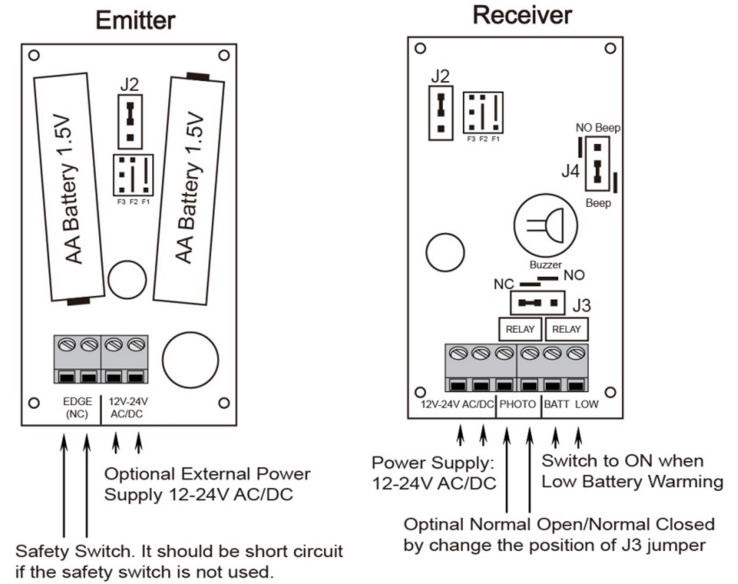

Wiring Connection with DSR/DSC 600/1000S sliding gate opener

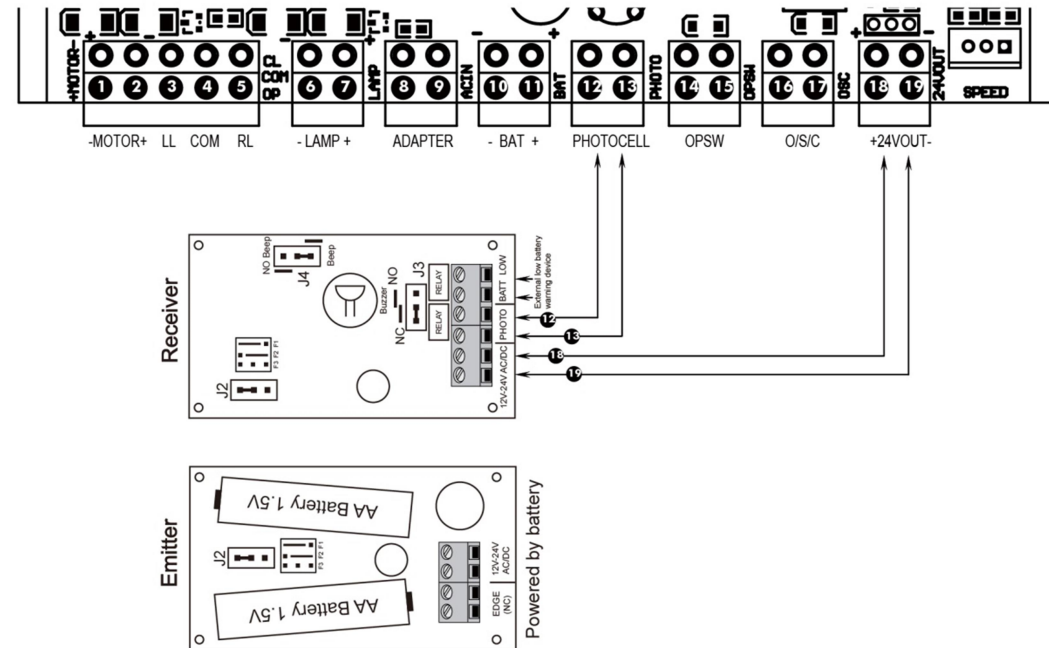

Wiring Connection with LM/MK series swing gate opener

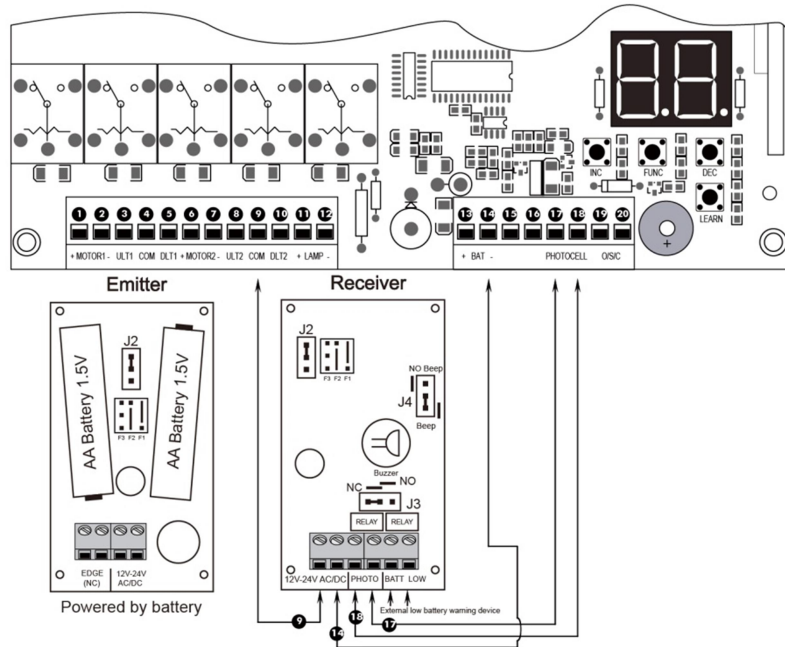

Wiring Connection with SAG/SCG 15/17/19 sliding gate opener

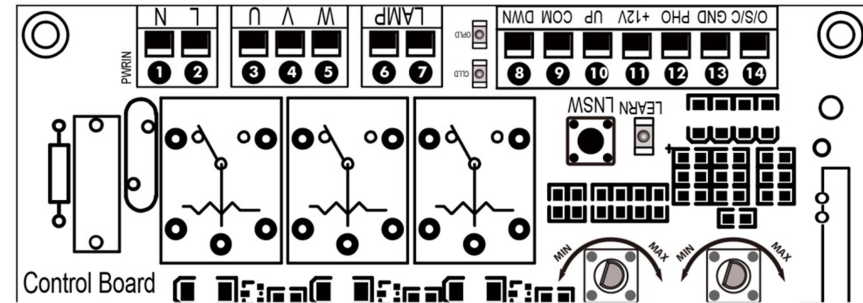
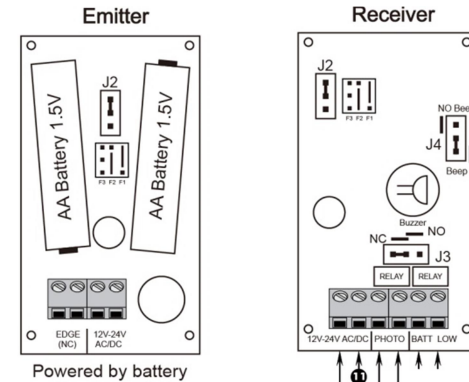

Wiring Connection with SFG/SCG 18/21/50H sliding gate opener

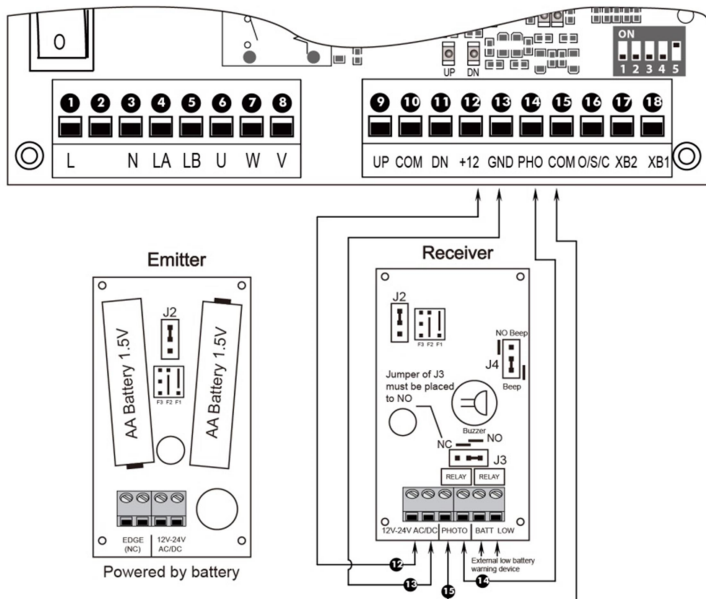

Installation

- Step 1: Fix the holder position paper on the wall and drill the installation hole.
- Step 2: Wiring and fixing the bottom cover to the wall and install the battery.
- Step 3: Screw the up cover and bottom cover together

