

GATE OPERATOR

**BIG**

**40QI**

**230 V**

Up to  
4000 kg

Speed up to  
18 m/min



### **500BIG40QI**

230 V three-phase sliding gate operator with built-in control unit with inverter. Max. gate weight 4000 kg.



**Accessories for  
BIG series**  
Page 46



**Further accessories:**  
Transmitters page 234  
Photocells page 239  
Flashing lights  
page 242

## FEATURES:

- commercial use
- for gates up to 4000 kg
- three-phase 230 V operator
- mono-phase 230 V power supply
- soft start and soft stop
- adjustable opening and closing speed of the control unit and inverter
- oil bath vertical pinion operator
- painted steel housing
- manual release mechanism
- mechanical clutch for crush prevention
- available upon request with pinion for M6 rack

## PROS:

- suitable for large sliding gates
- higher torque and power thanks to the inverter technology
- self-ventilated operator to increase the working cycle
- metal and bronze gears to increase endurance and reduce noise



### GEARMOTOR

Thanks to the oil bath gearbox, the three-phase ventilated gearmotor guarantees intensive and long-lasting use.



### UNLOCK

Thanks to the industrial mechanical key, the unlocking maneuver is always feasible even for particularly heavy gates.



### ELECTRONICS

The control unit with inverter allows to vary the speed and to program the acceleration and deceleration ramps.



### LIMIT SWITCH

The industrial limit switch, adjustable in height, is suitable for working with any type of rack.

## TECHNICAL DRAWINGS

### Technical features

### BIG40QI

Power supply	230 V AC (50 - 60 Hz)
Motor power supply	230 V AC
Open circuit voltage	3,6 A
Power rating	1500 W
Max. operating speed	adjustable 7 ÷ 18 m/min
Duty cycle	100 %
Operating temperature	-20° C ÷ +55° C
Motor thermal protection	150° C
Degree of protection	IP 54
Max. gate leaf weight	4000 kg
Max. weight cantilever gate leaf	2800 kg
Pinion module	4
Electronic control unit	D820M

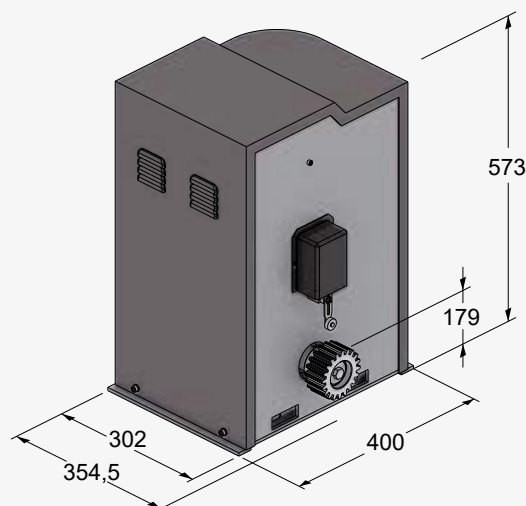

## BIG25QI TYPICAL SYSTEM

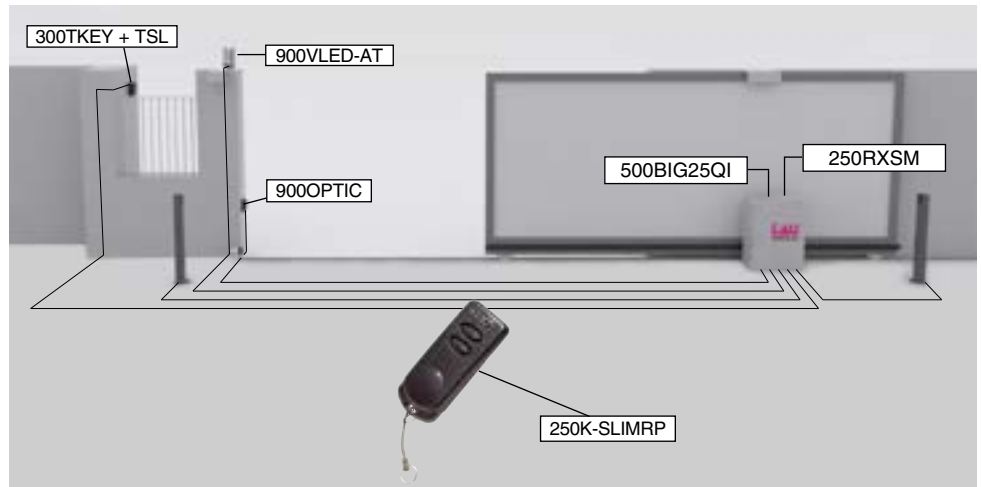

## BIG40QI TYPICAL SYSTEM

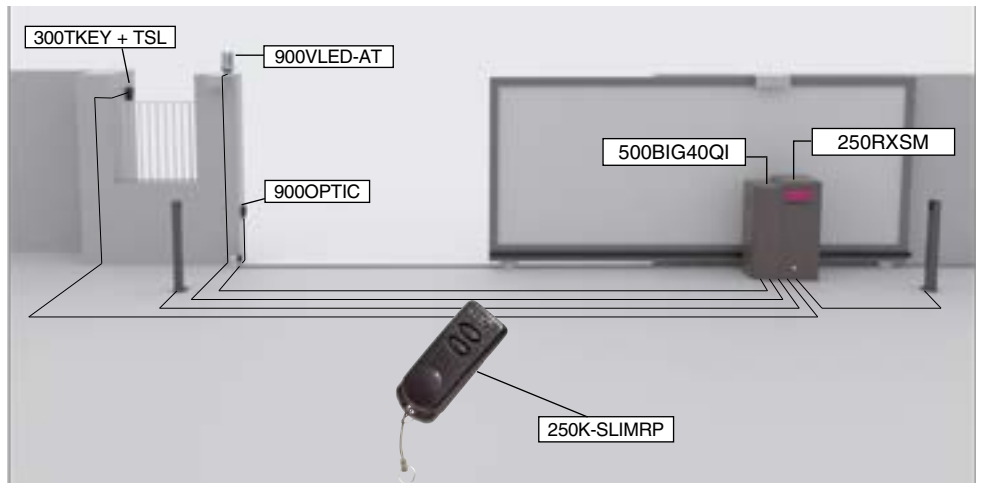

## CHAIN VARIANT



Upon request, the BIG gearmotor is available with the pinion for chain transmission and for foreign markets the 120 Volt variant is also available.

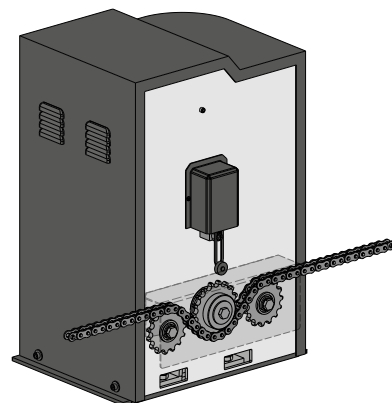

## Use and maintenance manuals



BIG



D820M