

BOB5024 / BOB5024E

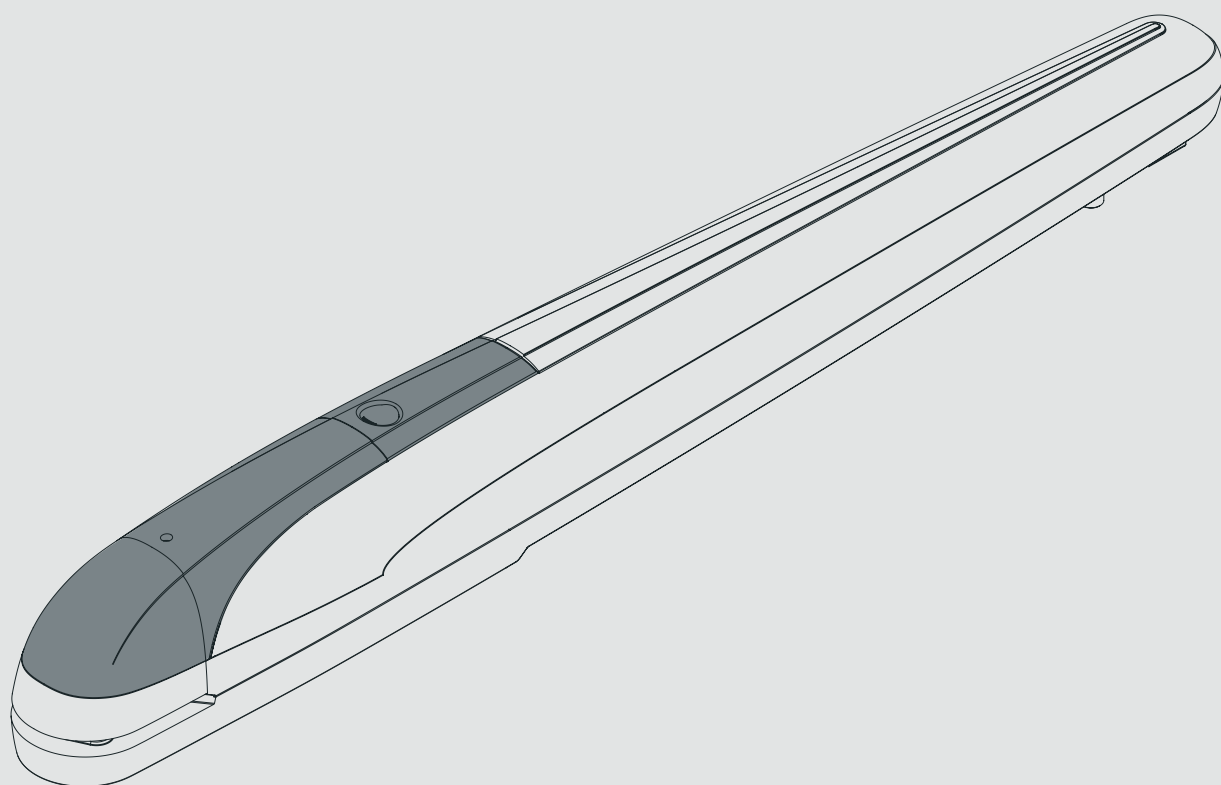

BENINCA[®]
TECHNOLOGY TO OPEN



Dimensioni d'ingombro / Overall dimensions / Abmessungen
Dimensions d'encombement / Dimensiones exteriores / Wymiary gabarytowe

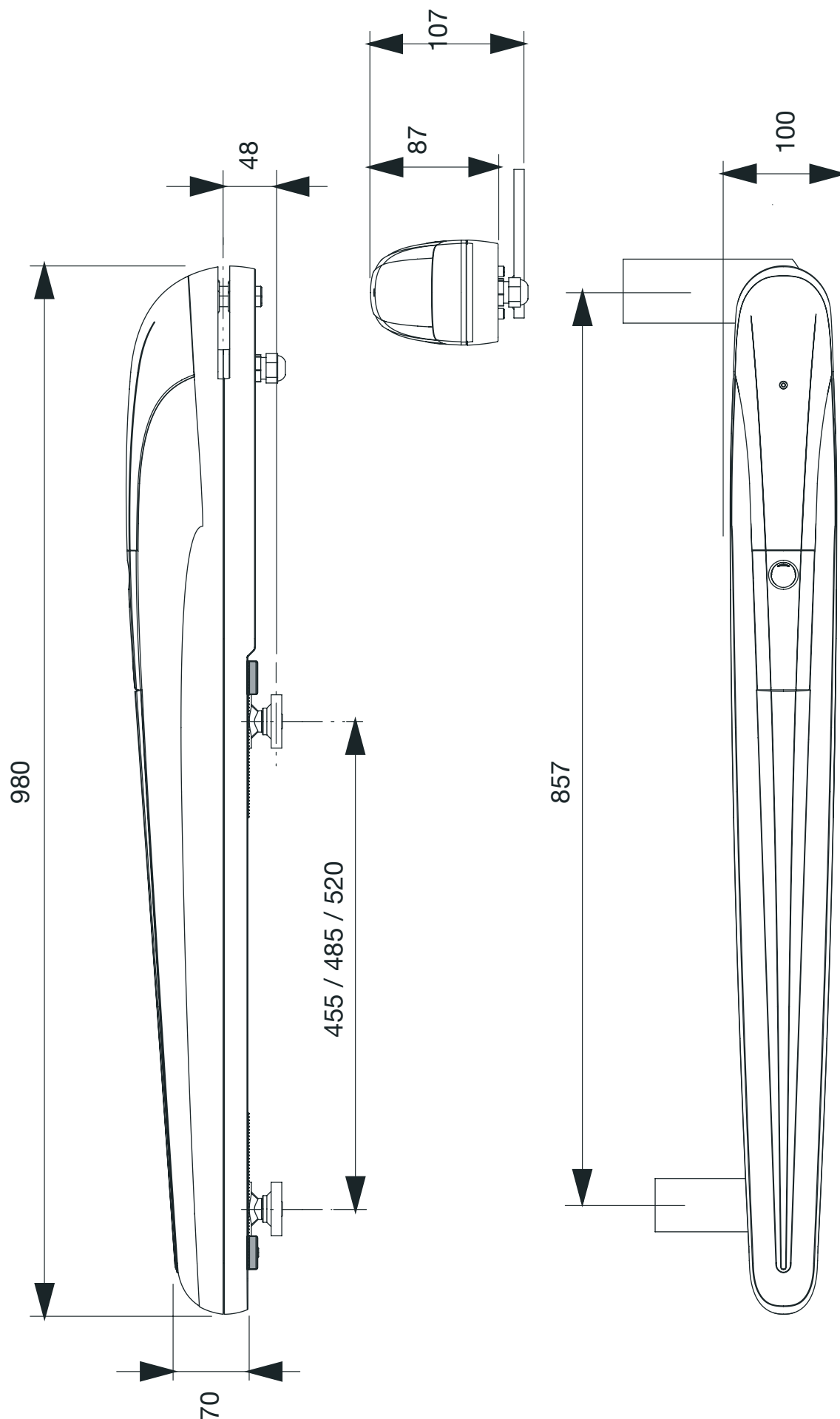

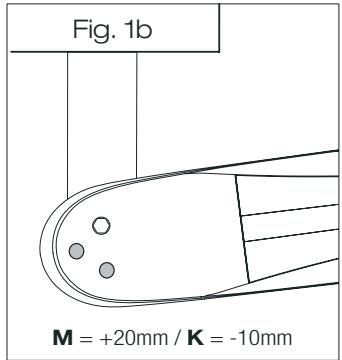
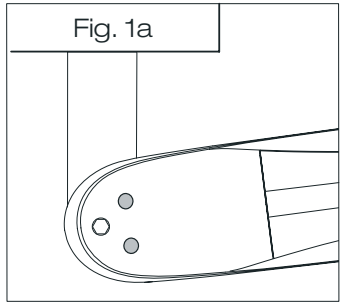
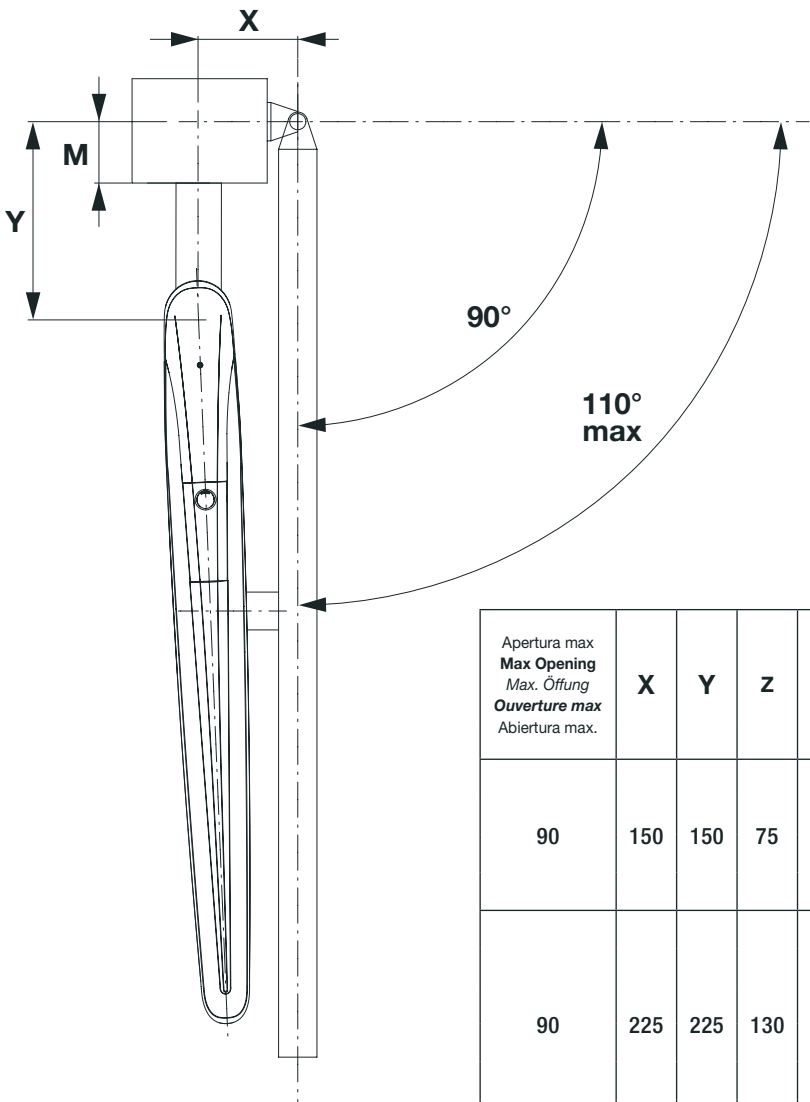
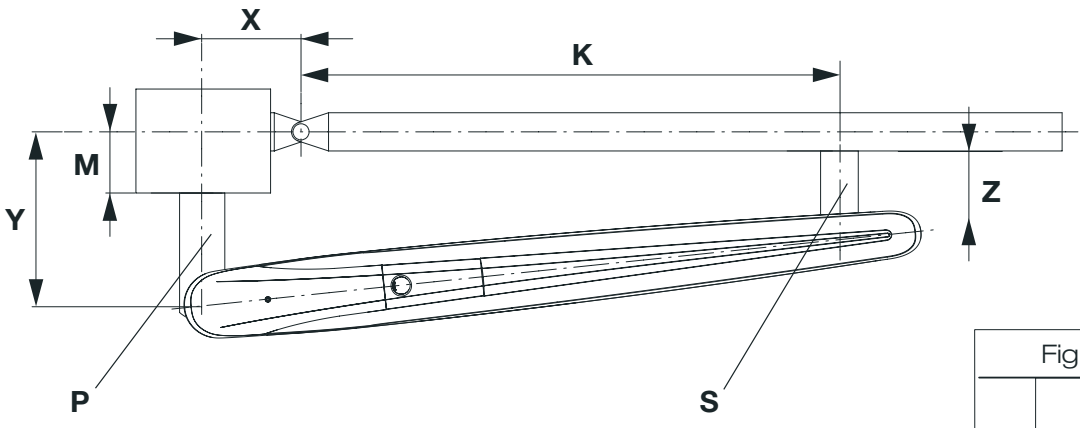

Apertura max Max Opening Max. Öffung Ouverture max Abiertura max.	X	Y	Z	K	M* max.	Tempo apertura Opening time Öffnungszeit Temps d'ouverture Tiempo de abiertura Prędkość kątowna (90°)	Dimensioni max anta Max wing dimensions Max Flügelmasse Dimens. max de la porte Dimens. max de la hoja	
							L (m)	P (kg)
90	150	150	75	695	90	25"	2,5	400
							3	350
							3,5	300
							4*	250
90	225	225	130	625	155	38"	2,5	500
							3	450
							3,5	400
							4*	350
							4,5*	300
100	200	200	110	650	130	34"	2,5	500
							3	450
							3,5	400
							4*	350
							4,5*	300
110	175	175	90	680	110	30"	2,5	400
							3	350
							3,5	300
							4*	250

- * Consigliabile l'utilizzo di elettroserratura
- * **It is advisable to use an electric lock**
- * Wir empfehlen den Einsatz eines Elektroschlusses
- * **On suggère l'utilisation d'une serrure électrique**
- * Aconsejado el empleo de la cerradura eléctrica
- * **Zaleca się zainstalowanie zamka elektrycznego**

2

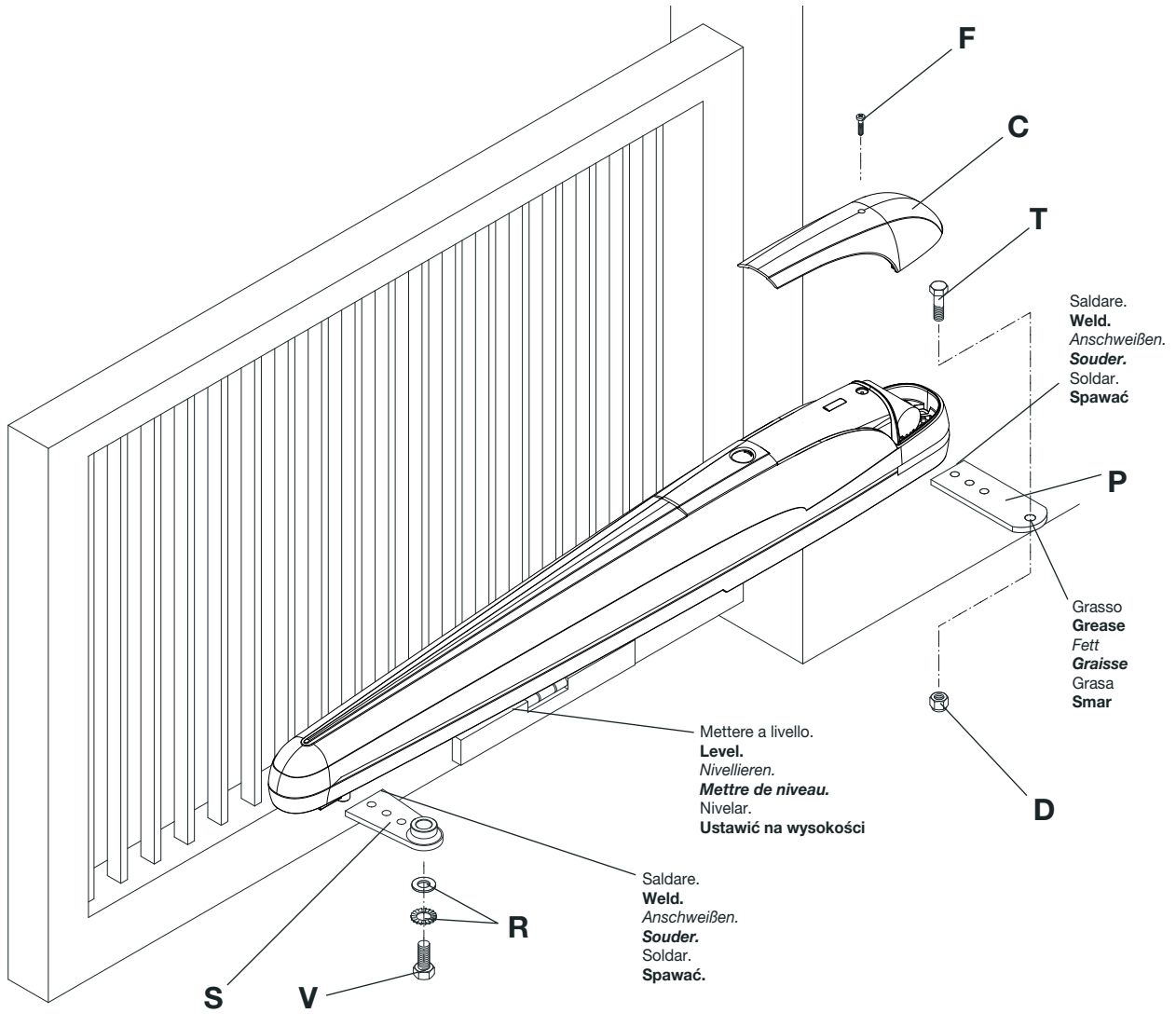

3

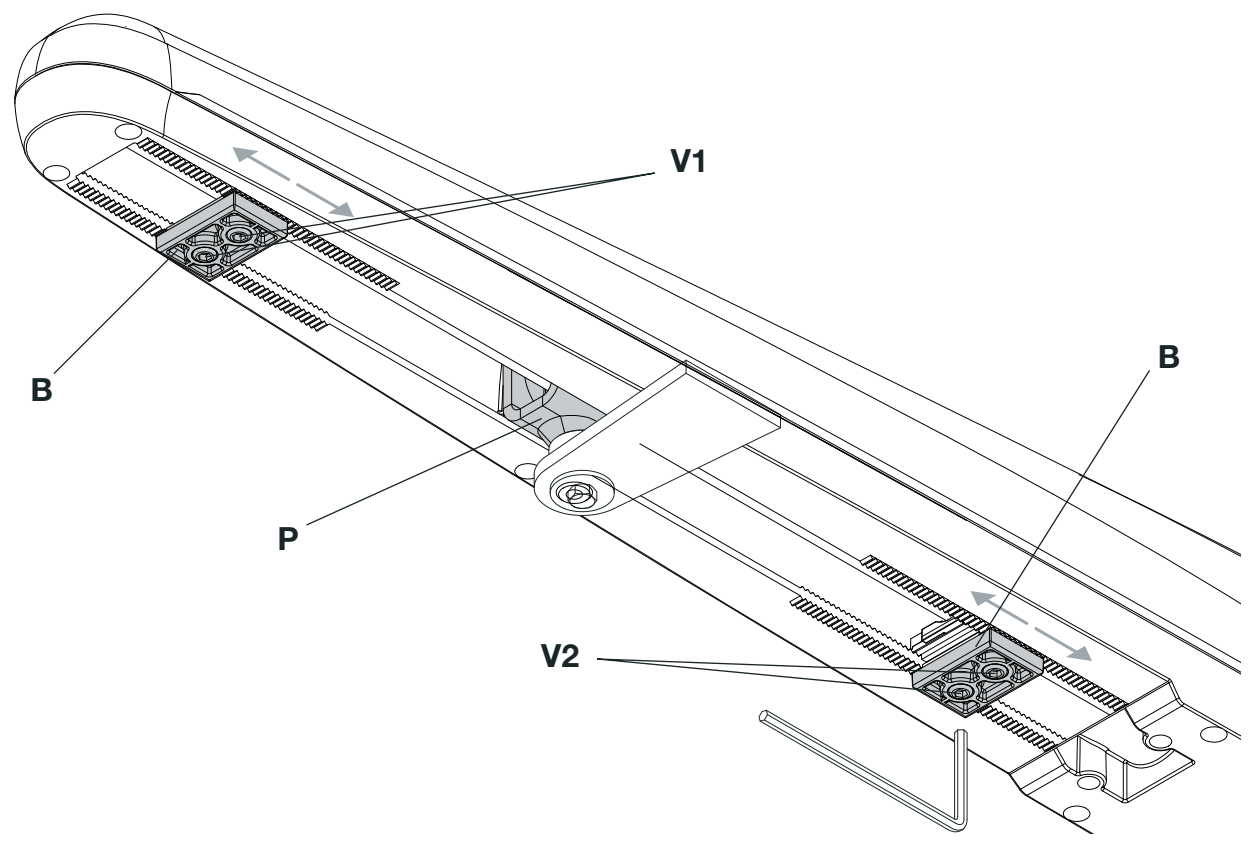

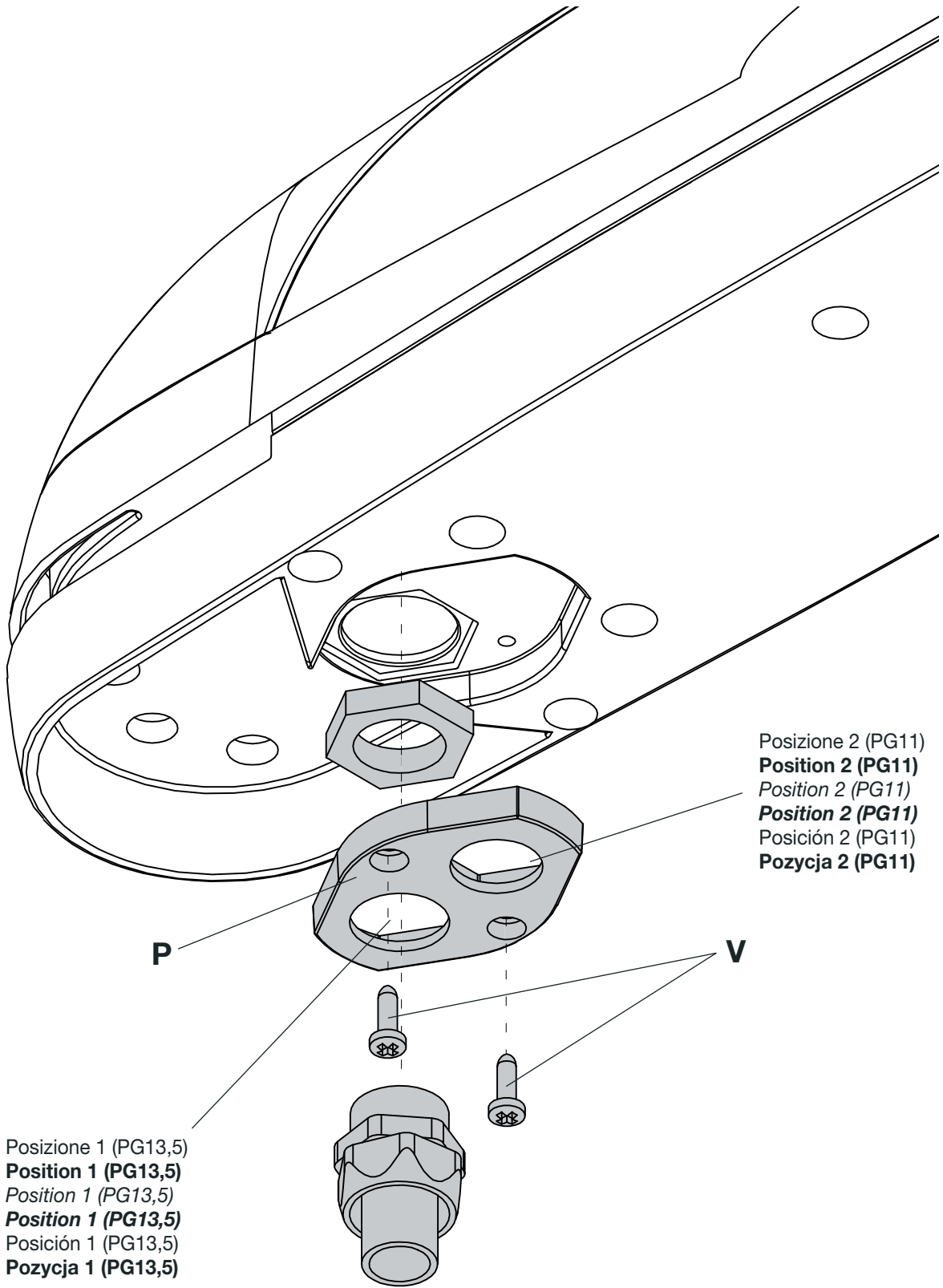

Posizione 2 (PG11)
Position 2 (PG11)
Position 2 (PG11)
Position 2 (PG11)
Posición 2 (PG11)
Pozycja 2 (PG11)

Posizione 1 (PG13,5)
Position 1 (PG13,5)
Position 1 (PG13,5)
Position 1 (PG13,5)
Posición 1 (PG13,5)
Pozycja 1 (PG13,5)

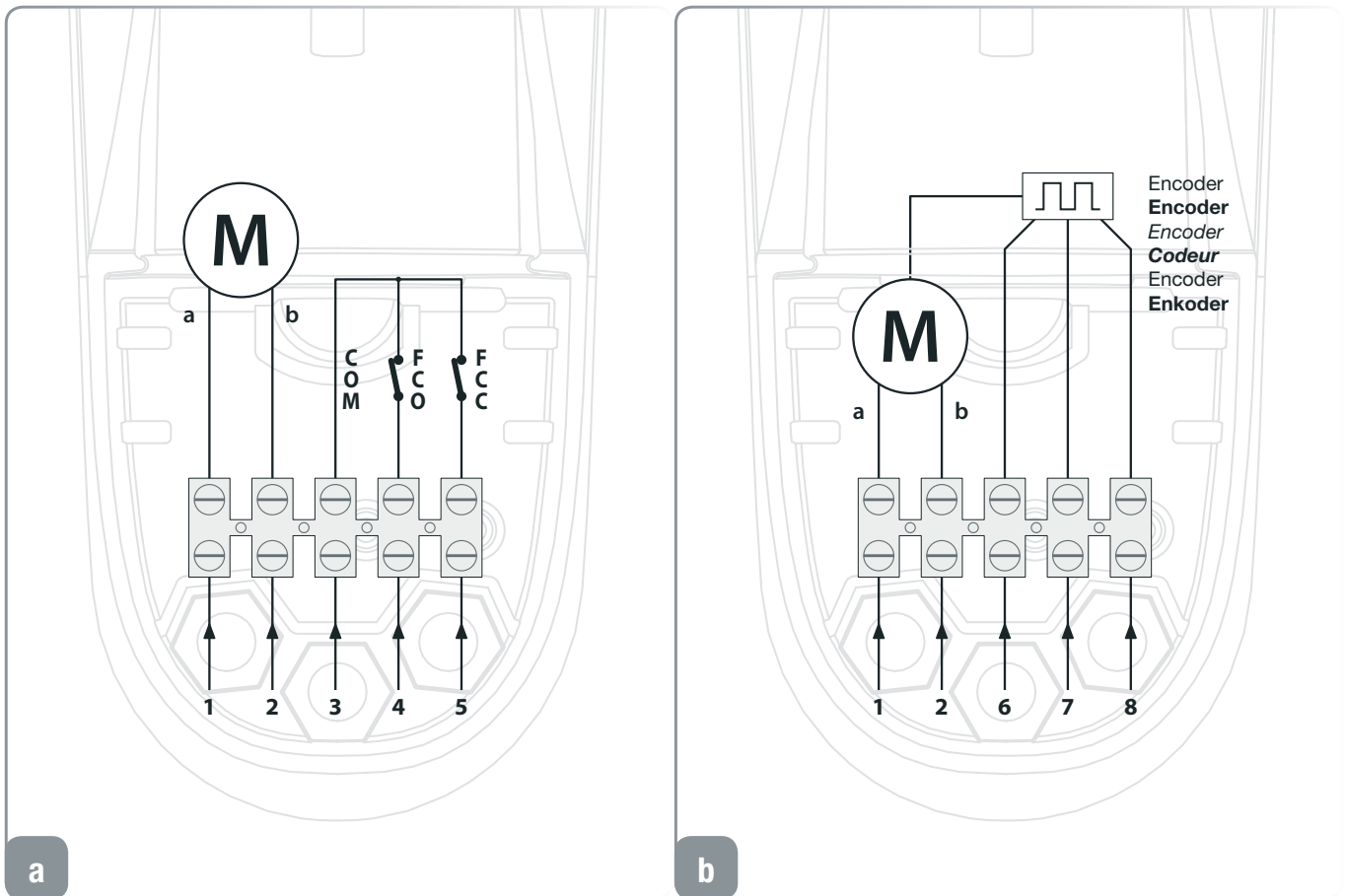

1	M+	M+	M+	M+	M+	M+
2	M-	M-	M-	M-	M-	M-
3	COM	COM	COM	COM	COM	COM
4	FCO	FCO	FCO	FCO	FCO	FCO
5	FCC	FCC	FCC	FCC	FCC	FCC
6	Segnale ENCODER	ENCODER signal	ENCODER-Signal	Signal ENCODEUR	Señal ENCODER	Sygnal ENKODERA
7	Positivo ENCODER	ENCODER positive	ENCODER Pluspol	Positif ENCODEUR	Positivo ENCODER	Dodatni ENKODERA
8	Negativo ENCODER	ENCODER negative	ENCODER Minuspol	Négatif ENCODER	Negativo ENCODER	Ujemny ENKODERA
a	Filo nero	Black wire	Schwarzer Leiter	Fil noir	Hilo negro	Czarny przewód
b	Filo rosso	Red wire	Roter Leiter	Fil rouge	Hilo rojo	Czerwony przewód
COM	COM finecorsa	Limit switch COM	COM Endschalter	COM fin de course	COM final de carrera	COM ogranicznik
FCC	Finecorsa CHIUDE	CLOSE limit switch	Endschalter SCHLIESSEN	Fin de course FERME	Final de carrera CIERRA	Ogranicznik ZAMYKA
FCO	Finecorsa APRE	OPEN limit switch	Endschalter ÖFFNEN	Fin de course OUVRE	Final de carrera ABRE	Ogranicznik OTWIERA

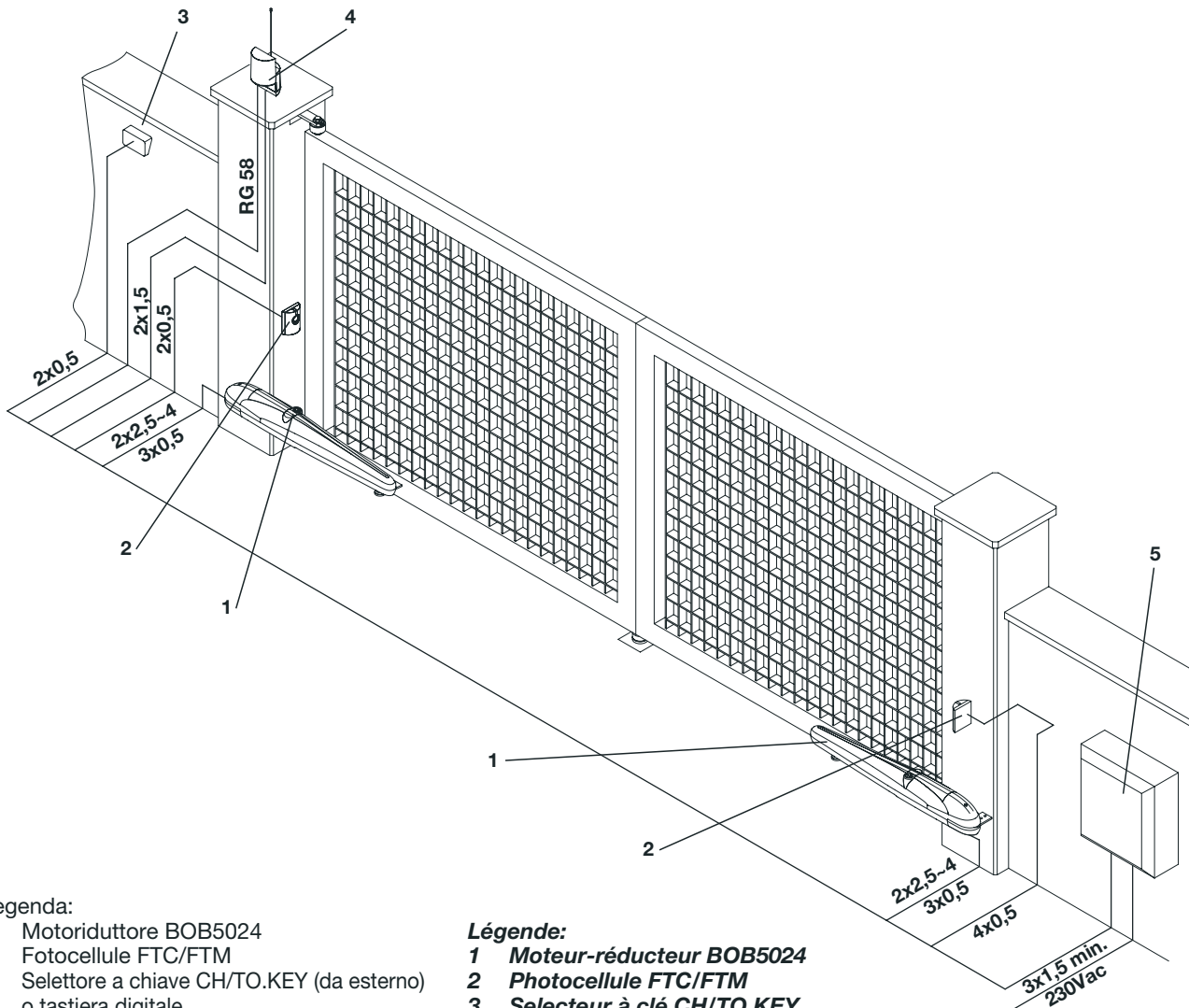

Legenda:

- 1 Motoriduttore BOB5024
- 2 Fotocellule FTC/FTM
- 3 Selettore a chiave CH/TO.KEY (da esterno) o tastiera digitale
- 4 Lampeggiante LAMPI24
- 5 Centrale elettronica BRAIN24.

Legenda:

- 1 Motoreductor BOB5024
- 2 Photo-electric cells FTC/FTM
- 3 Key selector CH/TO.KEY (external) or digital keyboard
- 4 Flash-light LAMPI24
- 5 Electronic board BRAIN24.

Zeichenerklärung:

- 1 Getriebemotor BOB5024
- 2 Fotozelle FTC/FTM
- 3 Schlüssel-Selektor CH/TO.KEY (außenliegend) oder Digital-Tastatur
- 4 Blinker LAMPI24
- 5 Elektroschrank BRAIN24.

Légende:

- 1 Moteur-réducteur BOB5024
- 2 Photocellule FTC/FTM
- 3 Selecteur à clé CH/TO.KEY (d'extérieur) ou clavier digital
- 4 Clignotant LAMPI24
- 5 Centrale électronique BRAIN24.

Legenda:

- 1 Motorreductor BOB5024
- 2 Fotocélulas FTC/FTM
- 3 Selectores a llave CH/TO.KEY (de superficie).
- 4 Relampagueador LAMPI24.
- 5 Central electrónica BRAIN24.

Objaśnienia:

- 1 Siłownik BOB5024
- 2 Fotokomórki FTC/FTM
- 3 Przełącznik kluczowy CH/TO.KEY (zewnętrzny) lub panel z przyciskami
- 4 Światło migające LAMPI24
- 5 Centralka elektroniczna BRAIN24

Tenere separati i cavi di potenza da quelli ausiliari. Per una lunghezza cavo inferiore a 5m utilizzare un cavo 2x2,5mm². Per un lunghezza cavo da 5m fino a 10m utilizzare un cavo 2x4mm². Collegamenti tra centrale e motore di lunghezza superiore ai 10m sono sconsigliati.

The power cables must be kept separated from the auxiliary cables. For cable length lower than 5m, use a cable 2x2.5sqmm. For cable length from 5 to 10 m use a cable 2x4sqmm. Cables longer than 10m are not recommended to connect control unit and motor.

Leistungskabel von Hilfskabeln getrennt halten. Bei einer Länge von weniger als 5 m muss ein Kabel 2x2,5mm² verwendet werden. Bei einer Länge von 5 m bis 10 m muss ein Kabel 2x4mm² verwendet werden. Anschlüsse zwischen Zentrale und Motor in einem größeren Abstand als 10 m sind nicht zu empfehlen.

Séparer les câbles de puissance des câbles auxiliaires. Pour un câble long moins de 5m utilisez un câble 2x2,5mm². Pour un câble long de 5m jusqu'à 10m utilisez un câble 2x4mm². Raccordements entre centrale et moteur ayant longueur supérieur à 10m sont déconseillés.

Tener separados los cables de potencia de los auxiliares. Para una longitud de cable menor que 5m utilizar un cable 2x2,5mm². Para una longitud de cable entre 5m y 10m utilizar un cable 2x4mm². Conexiones entre central y motor largas más de 10m están desaconsejadas.

Należy trzymać w oddali przewody zasilania od przewodów pomocniczych. Przy długości przewodu mniejszej niż 5 m należy używać przewodu 2x2,5 mm². Przy długości przewodu od 5 m do 10 m należy używać przewodu 2x4 mm². Sugeruje się nie stosować połączenia silnika z centralką przewodami o długości większej od 10 m.

EC Declaration of Conformity

Manufacturer: **Automatismi Benincà SpA.**

Address: Via Capitello, 45 - 36066 Sandrigo (VI) - Italia

Herewith declares that: the operator for hinged gates model **BOB5024 / BOB5024E.**

is complying with provisions set forth by the following other EC Directive:

- DIRECTIVE 2004/108/EC OF THE EUROPEAN PARLIAMENT AND OF THE COUNCIL of 15 December 2004, on the harmonisation of the laws of Member States relating to electromagnetic compatibility and which cancels Directive 89/336/EEC, according to the following harmonised regulations: EN 61000-6-2:2005, EN 61000-6-3:2007.

Benincà Luigi, Legal responsible.
Sandrigo, 10/06/2010.

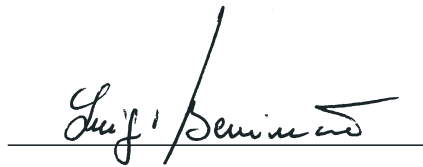

WARNING

The product shall not be used for purposes or in ways other than those for which the product is intended for and as described in this manual. Incorrect uses can damage the product and cause injuries and damages.

The company shall not be deemed responsible for the non-compliance with a good manufacture technique of gates as well as for any deformation, which might occur during use.

Keep this manual for further use.

Qualified personnel, in compliance with regulations in force, shall install the system.

Packaging must be kept out of reach of children, as it can be hazardous. For disposal, packaging must be divided the various types of waste (e.g. carton board, polystyrene) in compliance with regulations in force.

The installer must supply all information on the automatic, manual and emergency operation of the automatic system and supply the end user with instructions for use.



An omnipolar switch/section switch with remote contact opening equal to, or higher than 3mm must be provided on the power supply mains.. Make sure that before wiring an adequate differential switch and an overcurrent protection is provided.

Pursuant to safety regulations in force, some types of installation require that the gate connection be earthed.

During installation, maintenance and repair, cut off power supply before accessing to live parts.

Descriptions and figures in this manual are not binding. While leaving the essential characteristics of the product unchanged, the manufacturer reserves the right to modify the same under the technical, design or commercial point of view without necessarily update this manual.

Introduction

- Before installing the system, read the instruction herein.
- It is mandatory not to use the BOB 524 / BOB 524E item for applications different from those indicated in the instructions herein.
- Supply the end user with instructions for using this system.
- The end user should receive special instruction manual.
- All Benincà items are covered by an insurance policy for damages and injuries caused by manufacture faults. It is however required that the machine bear the CE marking and original Benincà parts be used.

General information

To ensure a good operation of these automatic devices, the gate to be automated should meet the following requirements:

- good strength and stiffness.
- hinges should have a minimum backlash and allow for smooth and regular manual operations.
- when closed, the gate leaves should correctly overlap for their entire height.

How to install the automatic system

Calculate the height of the system from the ground (it is advisable to define a position as much centred as possible with respect to the main door and in correspondence with a strong cross girder). Weld the plate P, following measures in Fig. 1.

With the door closed, weld bracket S to a cross beam of the main door or other element with equal strength, according to measures shown in Fig. 1. Keep in mind that, when carrying out this operation, the actuator should not be totally in a stroke end position.

Remove the cover C by loosening the screw F. Then fix the actuator to the plate P by means of the screw T and the nut D (Fig. 2). Lock the actuator to plate S by means of screw V and washer R.

The holes in the actuator (Fig. 1a-1b) help to keep to the optimum installation measures.

How to adjust the mechanical stoppers

The actuator is provided with adjustable mechanical stoppers in the opening and closing phases. The system is adjusted by suitably positioning the “Open” and “Close” mechanical locks, as shown hereunder (Fig.3):

- 1) Unlock the automatic system by using the special release lever, as shown in the instructions for the user (page 21-22).
- 2) Close the door/gate leaf.
- 3) Loosen screws V1 and move the “Close” lock until it reaches the pivot P, then tighten screws V1.
- 4) Open the door/gate leaf.
- 5) Loosen screws V2 and move the “Open” lock until it reaches the pivot P, then tighten screws V2.
- 6) Reset the automatic operating mode.

In the BOB 524 version, two limit micro-switches are provided fixed to the mechanical stoppers. The micro-switches trigger slightly in advance with respect to the mechanical stop.

Connections

- 1) The special plate P (Fig. 4) allows for using a link for sheath or cable gland PG11, or PG13,5. Once the type of cable gland is applied to the plate, fix the latter to the adaptor cover by means of screws V.
- 2) **BOB 524:** carry out the wiring by referring to the wire diagram shown in Fig 5a.
- 3) **BOB 524E:** carry out the wiring by referring to wire diagram shown in Fig 5b.
- 4) It is **mandatory** to provide for ground by using the **special GND terminal**.

WARNING

The insurance policy, which covers any damages or injuries caused by manufacture faults, requires that the installation comply with regulations in force and Benincà original accessories be used.

TECHNICAL DATA	BOB5024 BOB5024E
Power supply	24Vdc
Absorbed rating	120 W
Absorbed current	6 A
Thrust	2000 N
Jogging	intensive
Protection degree	IP54
Operating temperature	-20°C / +70°C
Door leaf max. weight	500 kg
Useful stroke: - with 2 mechanical stoppers - with 1 mechanical stopper - without mechanical stoppers	455 mm 485 mm 520 mm
Translation speed	0,8 m/min
Noise level	<70 dB
Lubrication	Permanent grease
Weight	11,6 kg

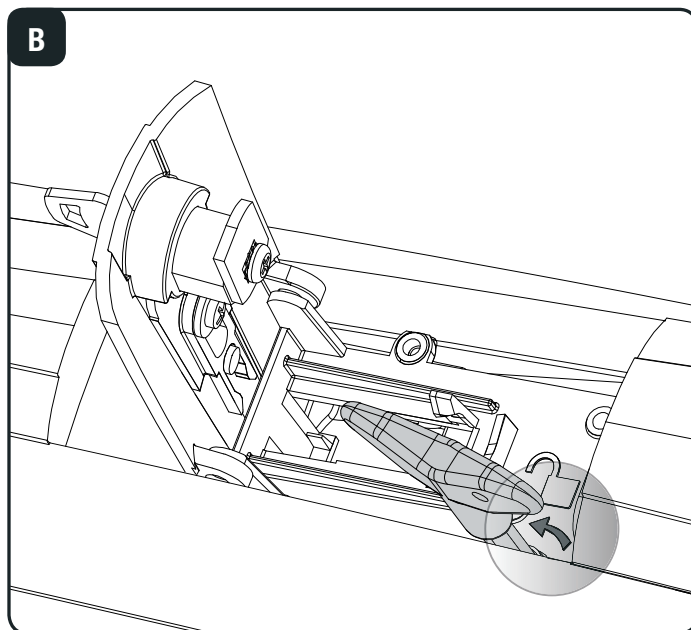
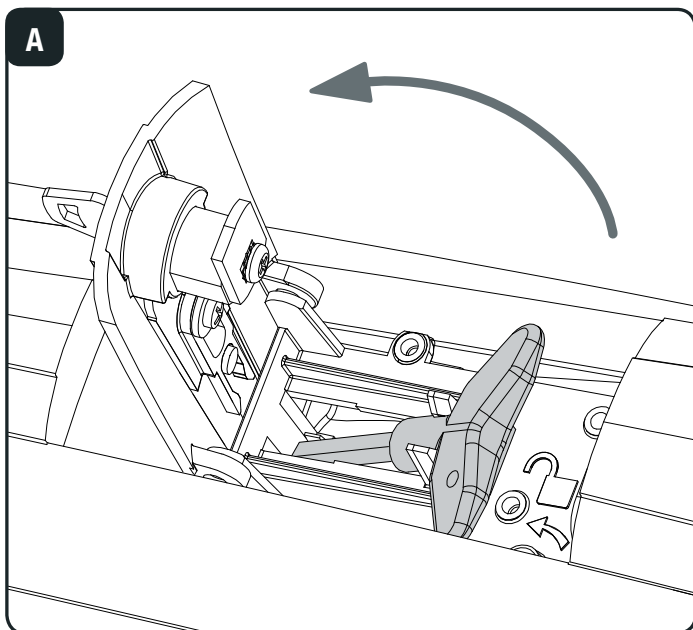

ITALIANO

Norme di sicurezza

- Non sostare nella zona di movimento della porta.
- Non lasciare che i bambini giochino con i comandi o in prossimità delle ante.
- In caso di anomalie di funzionamento non tentare di riparare il guasto ma avvertire un tecnico specializzato.

Manovra manuale e d'emergenza

In caso di mancanza dell'energia elettrica o di guasto, per azionare manualmente le ante procedere come segue:

- aprire lo sportellino di protezione del meccanismo di sblocco (fig. A);
- Inserire la speciale chiave di sblocco fornita in dotazione e ruotarla di 90°, come indicato dalla freccia sul carter evidenziata in figura B;
- è ora possibile aprire/chiedere manualmente l'anta;
- per ripristinare il funzionamento automatico, riportare la chiave di sblocco nella posizione iniziale;
- rimuovere la leva di sblocco e richiudere lo sportellino di protezione.

Manutenzione

- Controllare periodicamente l'efficienza dello sblocco manuale di emergenza.
- Astenersi assolutamente dal tentativo di effettuare riparazioni, potreste incorrere in incidenti; per queste operazioni contattare un tecnico specializzato.
- L'attuatore non richiede manutenzioni ordinarie, tuttavia è necessario verificare periodicamente l'efficienza dei dispositivi di sicurezza e le altre parti dell'impianto che potrebbero creare pericoli in seguito ad usura.

Smaltimento

Come indicato dal simbolo a lato, è vietato gettare questo prodotto nei rifiuti domestici in quanto alcune parti che lo compongono potrebbero risultare nocive per l'ambiente e la salute umana, se smaltite scorrettamente. L'apparecchiatura, pertanto, dovrà essere consegnata in adeguati centri di raccolta differenziata, oppure riconsegnata al rivenditore al momento dell'acquisto di una nuova apparecchiatura equivalente. Lo smaltimento abusivo del prodotto da parte dell'utente comporta l'applicazione delle sanzioni amministrative previste dalla normativa vigente.



Attenzione

Tutti i prodotti Benincà sono coperti da polizza assicurativa che risponde di eventuali danni a cose o persone causati da difetti di fabbricazione, richiede però la marcatura CE della "macchina" e l'utilizzo di componenti originali Benincà.

ENGLISH

Safety rules

- Do not stand in the movement area of the door.
- Do not let children play with controls and near the door.
- Should operating faults occur, do not attempt to repair the fault but call a qualified technician.

Manual and emergency operation

In the event of power failure or fault, to manually open and close the door/gate, proceed as follows:

- open the protection door of the release device (Fig. A);
- introduce the special release key supplied and turn it by 90°, as shown by the arrow on the removable cover highlighted in Figure B;
- now the door can be opened/closed by hand;
- to reset the automatic operation, move the release key to the initial position;
- remove the release lever and close the protection door.

Maintenance

- Every month check the good operation of the emergency manual release.
- It is mandatory not to carry out extraordinary maintenance or repairs as accidents may be caused. These operations must be carried out by qualified personnel only.
- The operator is maintenance free but it is necessary to check periodically if the safety devices and the other components of the automation system work properly. Wear and tear of some components could cause dangers.

Waste disposal

As indicated by the symbol shown, it is forbidden to dispose this product as normal urban waste as some parts might be harmful for environment and human health, if they are disposed of incorrectly. Therefore, the device should be disposed in special collection platforms or given back to the reseller if a new and similar device is purchased. An incorrect disposal of the device will result in fines applied to the user, as provided for by regulations in force.



Warning

All Benincà products are covered by insurance policy for any possible damages to objects and persons caused by construction faults under condition that the entire system be marked CE and only Benincà parts be used.

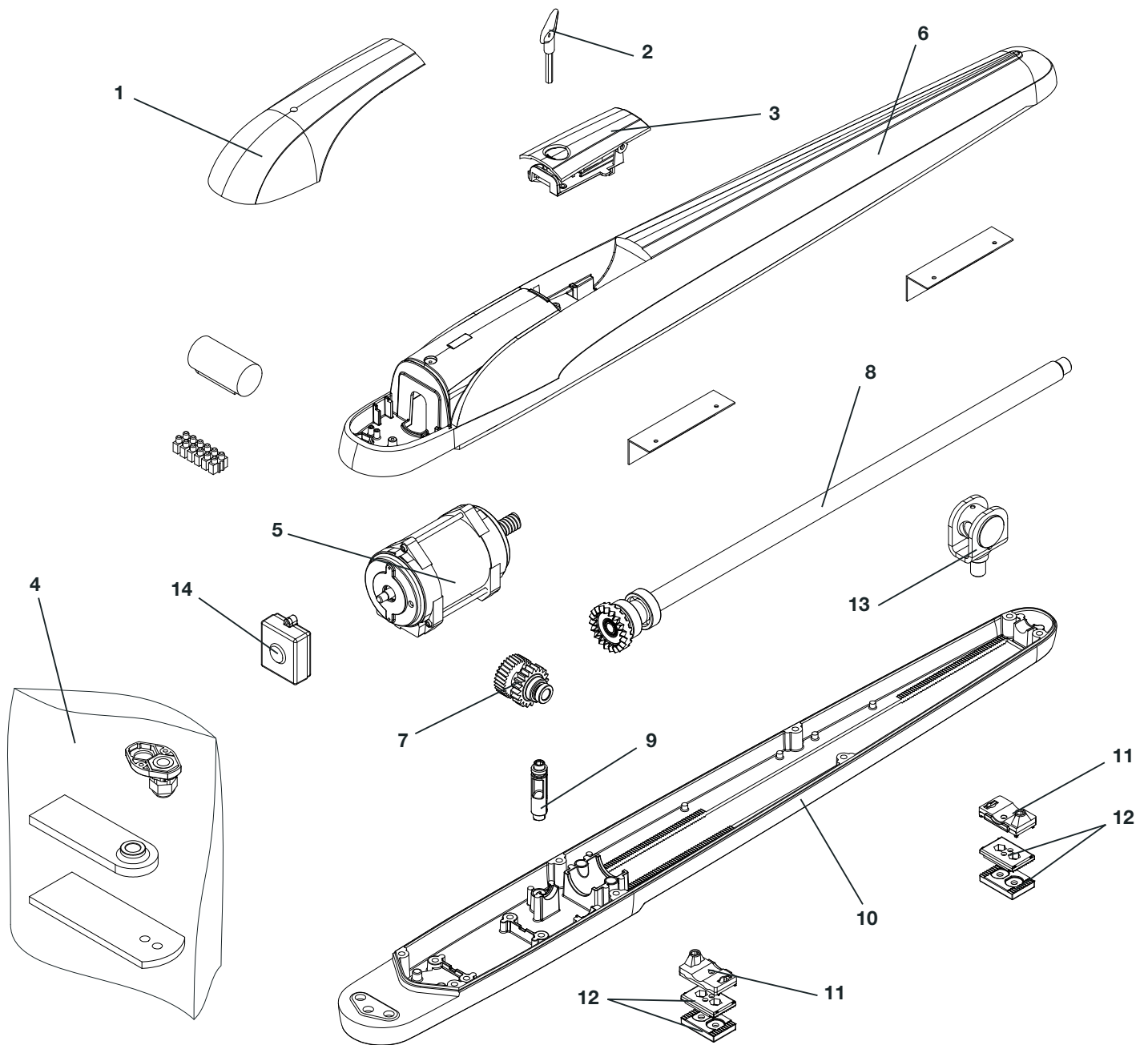

n°	BOB5024 / BOB5024E						Cod.
	Denominazione - Description - Bezeichnung - Dénomination - Denominación - Określenie						
1	Copertura plastica	Plastic cover	<i>Plastikabdeckungen</i>	<i>Couverture plast.</i>	Cubierta de plástico	Obudowy Plastykowe	9686630
2	Leva di sblocco	Release lever	<i>Entriegelungshebel</i>	<i>Levier de déblocage</i>	Palanca de desbloq.	Dźwig. odblokowująca	9686631
3	Gruppo sblocco	Unblock. group	<i>Ent. Gruppe</i>	<i>Déblocage</i>	Desbloqueo	Zespół odblok.	9686632
4	Blister	Blister	<i>Blister</i>	<i>Blister</i>	Blister	Blister	9686633
5	Motore	Motor	<i>Motor</i>	<i>Moteur</i>	Motor	Silnik	9686643
6	Carter superiore	Upper cover	<i>Gehäuse</i>	<i>Carter</i>	Cárter	Karter	9686635
7	Ingranaggio di riduzione	Gear	<i>Zahnrad</i>	<i>Engrange</i>	Engranaje	Koło zębate	9686636
8	Vite senza fine	Worm screw	<i>Welle</i>	<i>Vis sans fin</i>	Tornillo sin fin	Śruba dwustronna	9686637
9	Perno di sblocco	Lock with pin	<i>Entblockung</i>	<i>Plaque avec pivot</i>	Bloqueo	Chwytek blok.	9686638
10	Carter inferiore	Lower cover	<i>Gehäuse</i>	<i>Carter</i>	Cárter	Karter	9686639
11	Finecorsa (solo BOB 524)	Limit stop (Only BOB 524)	<i>Endschalter (Nur BOB 524)</i>	<i>Fin de course (Seulement BOB 524)</i>	Final de carrera (Sólo BOB 524)	Krańcówka (Tylko BOB 524)	9686640
12	Fermi meccanici	Locks	<i>Blöcke</i>	<i>Blocages</i>	Bloques	Blokady	9686641
13	Madrevite con forcella	Wormscrew supp.	<i>WelleStütze</i>	<i>Support vis sans fin</i>	Soporte tornillo sin fin	Zaczep śruba dwustron.	9686642
14	Encoder (solo BOB 524E)	Encoder (Only BOB 524E)	<i>Encoder (Nur BOB 524E)</i>	<i>Encodeur (Seulement BOB 524E)</i>	Encoder (Sólo BOB 524E)	Enkoder (Tylko BOB 524E)	9686516