

Specifications

Frequency:	433.39 MHz
Security:	128-bit AES encryption
Range:	up to 30 metres
Battery life:	up to 10 years
Battery type:	14500 mA battery



Wireless Vehicle Detection System

EL00IG and EL00IG-RAD

Installation in 3 simple steps

STEP 1:

Coding e-LOOP into e-Trans 50

Coding e-LOOP without magnet

1. Power up the **e-TRANS-50** and hold the e-Loop within 10cm of the transceiver's antenna.
2. Now press and release the CODE button on the e-Trans 50. The yellow and red LEDs will flash on the e-Loop, and the blue LED on the **e-TRANS-50** will flash 3 times. The systems are now paired.

NOTE: For coding **e-TRANS-200** LCD transceivers, refer to **e-TRANS-200** manual.

Coding e-LOOP with magnet

1. Power up the **e-TRANS-50**, then press and release the CODE button. The blue LED on the **e-TRANS-50** will light up.
2. Now place the magnet on the CODE recess on the e-Loop – the yellow LED will flash 3 times, and the blue LED on the e-Trans 50 will flash 3 times. The systems are now paired and you can remove the magnet.

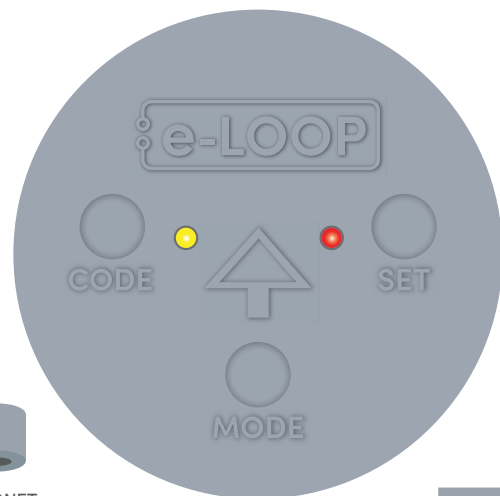

STEP 2: Fitting e-LOOP

(Refer to diagram below)

1. Drill a 89-92mm hole, 65-70mm deep. Ensure hole is clean and dry before fitting.
2. Measure down before inserting the e-LOOP to ensure it will fit flush with the driveway surface, then pour sikaflex or similar compound into the base of hole.
3. Insert the e-LOOP by pushing down until flush with driveway surface.

NOTE: Never fit near high voltage cables, this can affect the e-LOOP's detection capability.

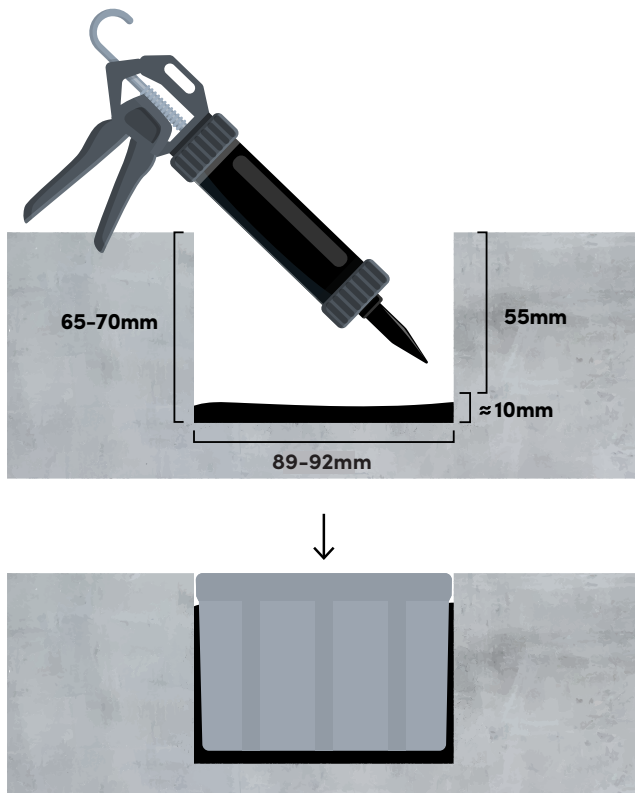

STEP 3: Calibrate e-LOOP

1. Move any metal objects away from the e-LOOP.
2. Place magnet into the SET button recess on the e-LOOP until the red LED flashes twice, then remove the magnet.
3. The e-LOOP will take about 5 seconds to calibrate and once complete, the red LED will flash 3 times.

System is now ready.

NOTE: After calibration you may get an error indication.

ERROR 1: Low radio range - yellow LED flashes 3 times before red LED flashes 3 times.

ERROR 2: No radio connection - yellow and red LED flashes 3 times before red LED flashes 3 times.

Uncalibrate e-LOOP

1. Place magnet into the SET button recess until red LED flashes 4 times, e-LOOP is now uncalibrated.

Changing mode

You can change the mode by using the **e-TRANS-200** LCD transceiver or diagnostic remote ED00R – refer to manual.

NOTE: This menu cannot be accessed via the **e-TRANS-50** Transceiver.

The e-LOOP EL00IG is set to EXIT mode (this can't be changed).

Parameters that can be altered:

- 1) Activation detection level
- 2) X, Y, Z axis sensitivity

Parameters that can be altered on EL00IG-RAD:

- 1) Mode is set to PRESENCE but can be changed to EXIT mode. **NOTE:** do not use presence mode as a personal safety device.
- 2) Activation detection level
- 3) X, Y, Z axis sensitivity
- 4) Radar read time
- 5) Release trip point
- 6) Start lens detection range
- 7) Measure lens detection range
- 8) Radar trip sensitivity
- 9) Radar confirm ON/OFF

