

www.automaticgatesolutions.com.au

Exit Wand

Installation and Operation Instructions

(Item NO.: LM 157)



NOTE: The exit wand is only to be installed after the gate opener has been set up and running well.

NOTE: Please read this manual thoroughly before installation.

NOTE: The wand may sense a bicycle, tricycle or other equipment include mass of metal which would activate the gate opener.

NOTE: To ensure your home security, we strongly recommend you to set Auto Close function of the gate opener when the loop detector (LM155) or exit wand (LM157) is used.

Thank you for your purchase of the EXIT WAND (LM157). This product is designed to be used with most brands Gate Opener by providing hands free operation of your gate. The gate opens automatically when the wand senses the vehicle moving past. The LM157 EXIT WAND is comprised of two elements: the WAND with 5-core cable, and range adjustment board.

Package Includes



Installation

NOTE: Before you permanently install the EXIT WAND, you should determine where to place the wand sensor and prepare some PVC conduit to route the cable to the control box. We recommend that the cable be run in PVC conduit to the control box to prevent damage to the cable from lawn mowers, weed eaters and grazing animals.

Determine where to place the wand sensor

Firstly please ensure the distance from the wand to the gate full open position is more than 7.5 metres.

Secondly please take note that the radius of the sense range of the wand is 600-3600mm, so please install the wand as near to the driveway as much as possible to ensure the wand can sense the vehicle passing.

Thirdly please note that you should leave 1.5 metres of cable for connecting from the ground to control board, that means the distance from the wand to the control box should not exceed 13.5 metres.

You can determine the place to install the wand according to above three points.

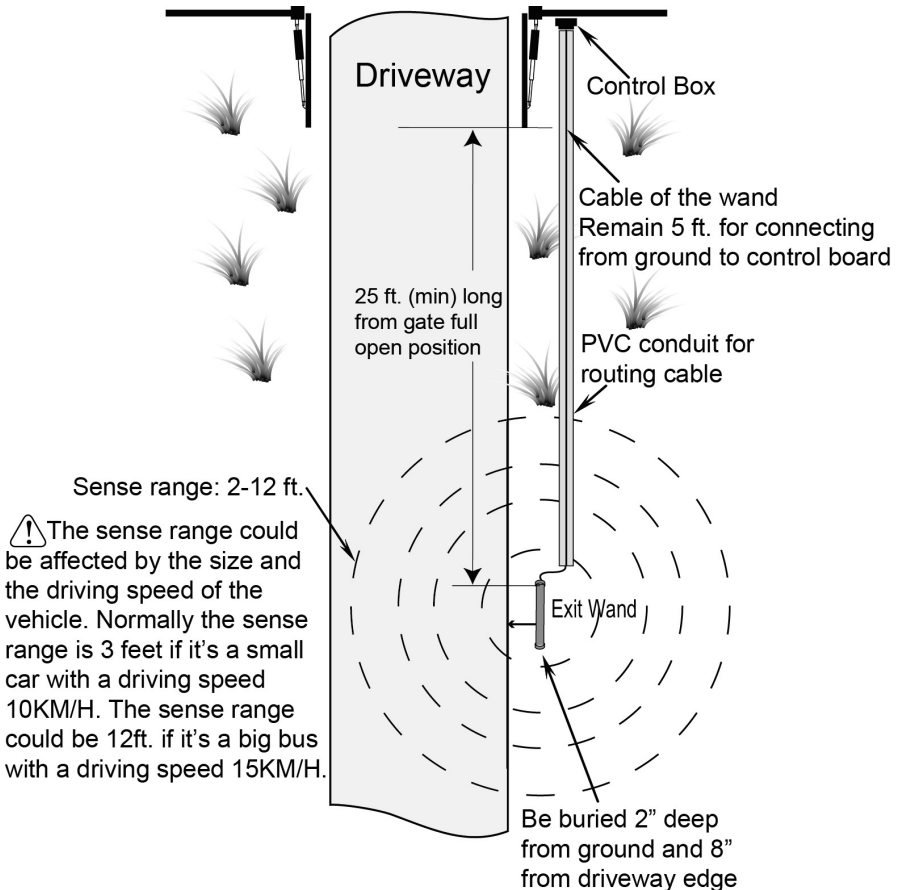

Installing

Once the place of the wand has been determined, you can start installing the wand. Dig a hole approximately 100mm deep and 600mm long within 250mm and parallel to the edge of the driveway.

Next, dig a trench from this hole to a spot under the gate opener control box to run the cable from the WAND to the control box. Size of the trench is related to the size of the PVC conduit.

Keep the WAND and the cable uncovered before the function has been tested OK. .

Wiring the WAND to gate controllers.

Definition of the 5 –core cable:

- RED → Input Voltage (+)
- GREEN → Ground/Common (-)
- BLACK → Relay's Common
- BLUE → Relay's Normally Open
- YELLOW → Range adjustment potentiometer (POT)

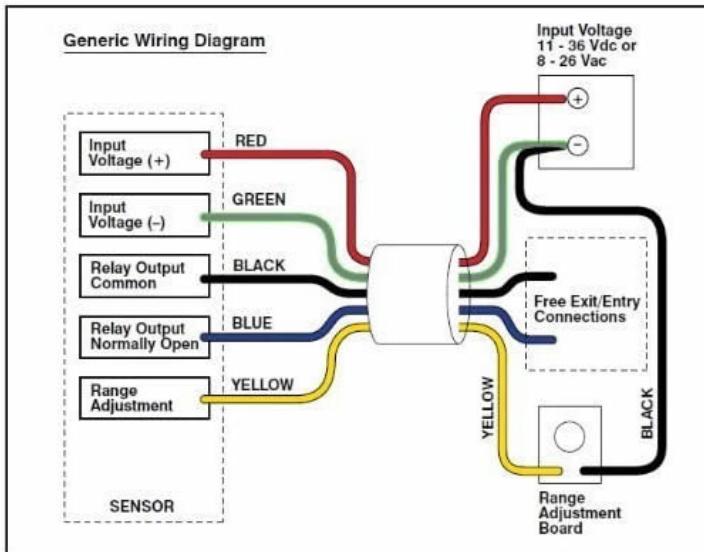

Power supply connection:

DC power supply (8-36 VDC)

Connect the positive (+) wire of the power supply to the RED wire.

Connect the negative (-) wire of the power supply to the GREEN wire.

AC power supply (8-24 VAC)

Connect the power supply to the RED and GREEN wire, no matter the polarity of the wires.

Relay output connection:

Connect the BLUE wire of the WAND to the 'FREE EXIT/ENTER' of the gate opener.

Connect the BLACK wire of the WAND to the 'COMMON/GND' of the gate opener.

Range adjustment board connection:

Connect the YELLOW wire of the WAND to one wire of the range adjustment board.

Connect the GREEN wire of the WAND to another wire of the range adjustment board which is the negative (-) input voltage.

Testing

NOTE: Please make sure there is no moving metal object with the range of the sensor when the WAND is first powered up and please wait for 60 seconds which allow the WAND self test and environment calibrations.

After installation and wiring the WAND, you must test the WAND to see if it is working properly and if the range needs adjusting for optimum performance.

Turn the potentiometer (POT) clockwise to increase range.

Turn the potentiometer (POT) counter-clockwise to decrease range.

Cover the WAND and the cable (PVC conduit) after everything is tested OK.

Trouble Shooting

If the WAND is not working:

Make sure all connections are correct.

Make sure the Range Adjustment is set at maximum range.

Disconnect the power to the WAND.

Reconnect the power to the WAND and make sure that no metal object or vehicle is moving around the WAND for 60 seconds while it is calibrating.

Test the WAND to verify that it is working properly.