

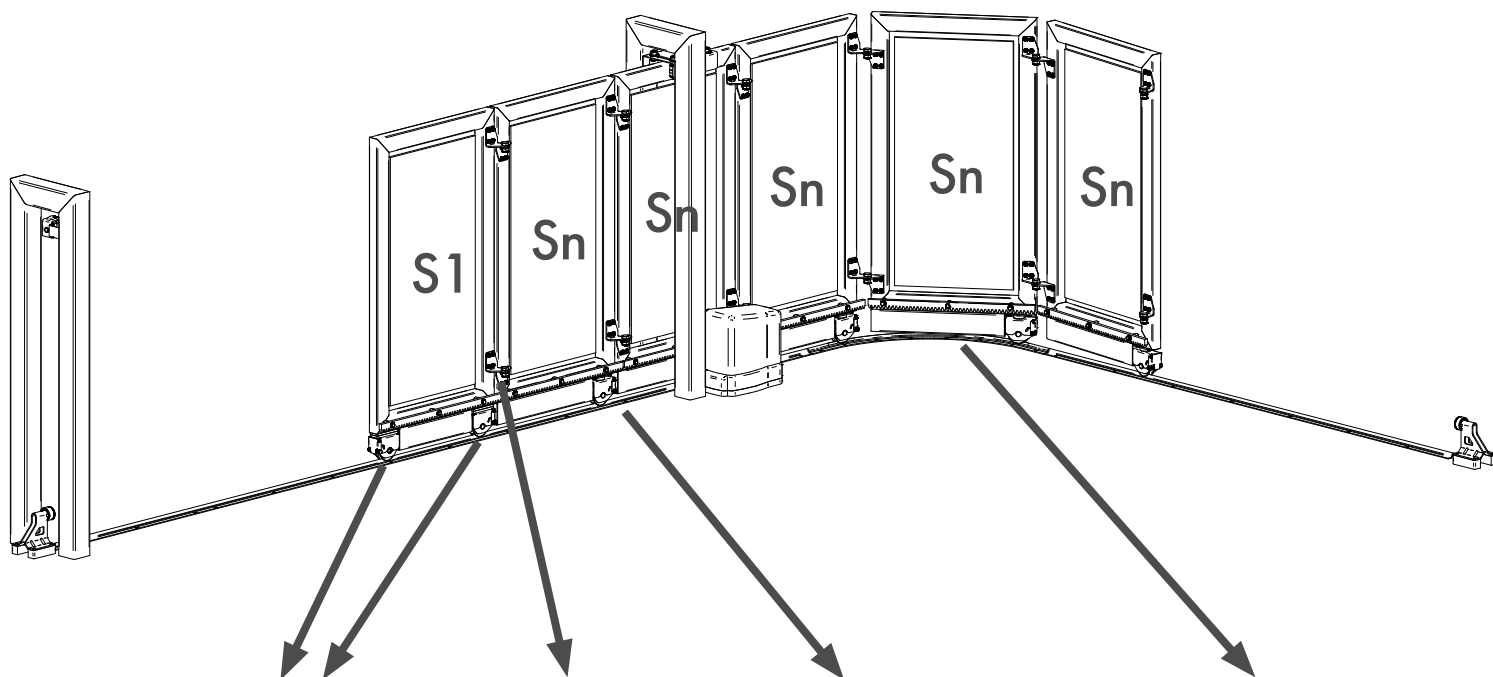

**KIT RADIUS - CANCELLO SEZIONALE**  
**KIT RADIUS - CORNER GATE**

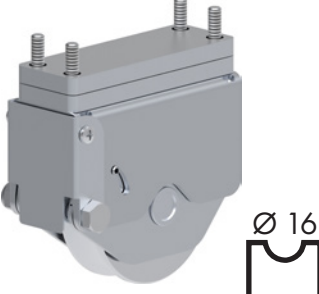

Kit di accessori in acciaio zincato per cancelli sezionali

Corner gate kit with galvanised steel accessories

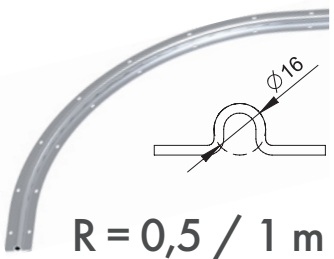

 <p>Ø 16</p>		 <p>360°</p> <p>Ø 16</p>	 <p>Ø 16</p> <p>R = 0,5 / 1 m</p>
<p>Ruote fisse per anta S1 Leaf S1 with fixed wheels</p>	<p>Cerniere Hinges</p>	<p>Ruota girevole per ante Sn Leaf Sn with rotating wheel</p>	<p>Rotaia curva Curved rail</p>

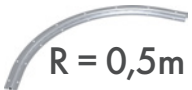
**KA8103 KIT ANTA PRINCIPALE S1 / KIT MAIN LEAF S1**



<p>KA8103.050</p>	<p>Rotaia curva R 0,50 m / Curved rail R 0,50 m Ante da 0,4 a 0,75 m / Leaves from 0,4 to 0,75 m</p>	 <p>R = 0,5m</p>
<p>KA8103.100</p>	<p>Rotaia curva R 1 m / Curved rail R 1 m Ante da 0,4 a 1,5 m / Leaves from 0,4 to 1,5 m</p>	 <p>R = 1m</p>

**KA8103.001 KIT ANTA SECONDARIA Sn / KIT SECONDARY LEAF**

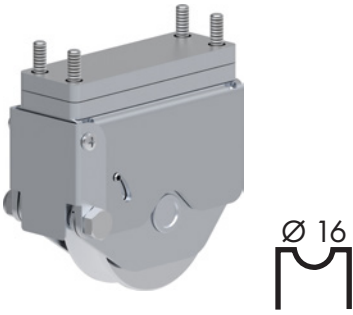
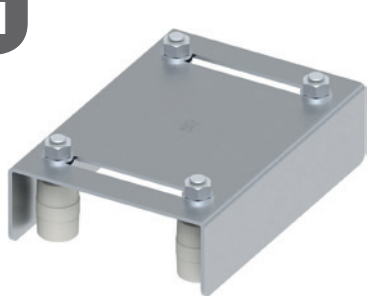

COMPONENTI  
COMPONENT LIST

KA8103.050/.100 KIT ANTA PRINCIPALE S1 / KIT MAIN LEAF S1

<p>x2</p>  <p>VA1321.075</p>	<p>x1</p>  <p>VA3205.B40</p>	<p>x2</p>  <p>VA4112.125</p>
<p>x1</p>  <p>R = 0,5 / 1 m</p> <p>VA2312</p>		

KA8103.001 KIT ANTA SECONDARIA S<sub>n</sub> / KIT SECONDARY LEAF S<sub>n</sub>

<p>x1</p>  <p>VA1322.075</p>	<p>x2</p>  <p>VL4600.135</p>	
---	---	--



ARTICOLI CORRELATI  
RELATED ARTICLES

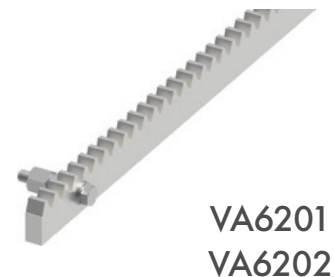



DIMENSIONAMENTO  
DIMENSIONING

PESO ANTA LEAF WEIGHT	PESO CANCELLO MAX GATE WEIGHT	SPESSORE TUBOLARE T TUBULAR THICKNESS T
min 15 - max 100 Kg	500 Kg	min 40 - max 80 mm

**S1** = Anta principale = sempre 1 PZ  
Main Leaf = always 1 PIECE

**Sn** = Ante secondarie  
Secondary leaves

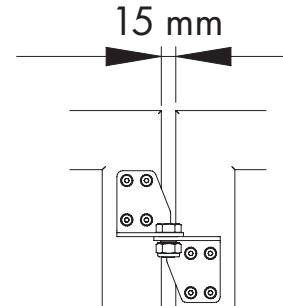
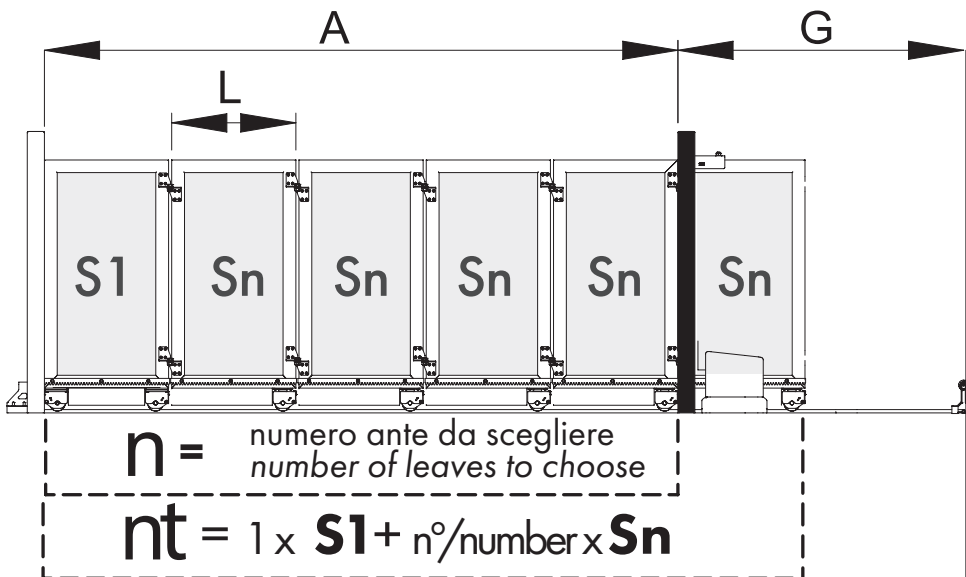

**E** min 0,35m/max = L

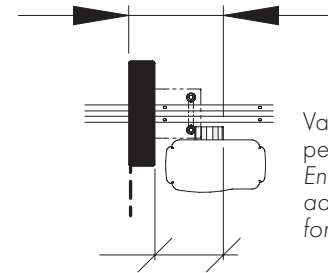

Valutare spazio per il motore  
Ensure you leave adequate space for the gate motor

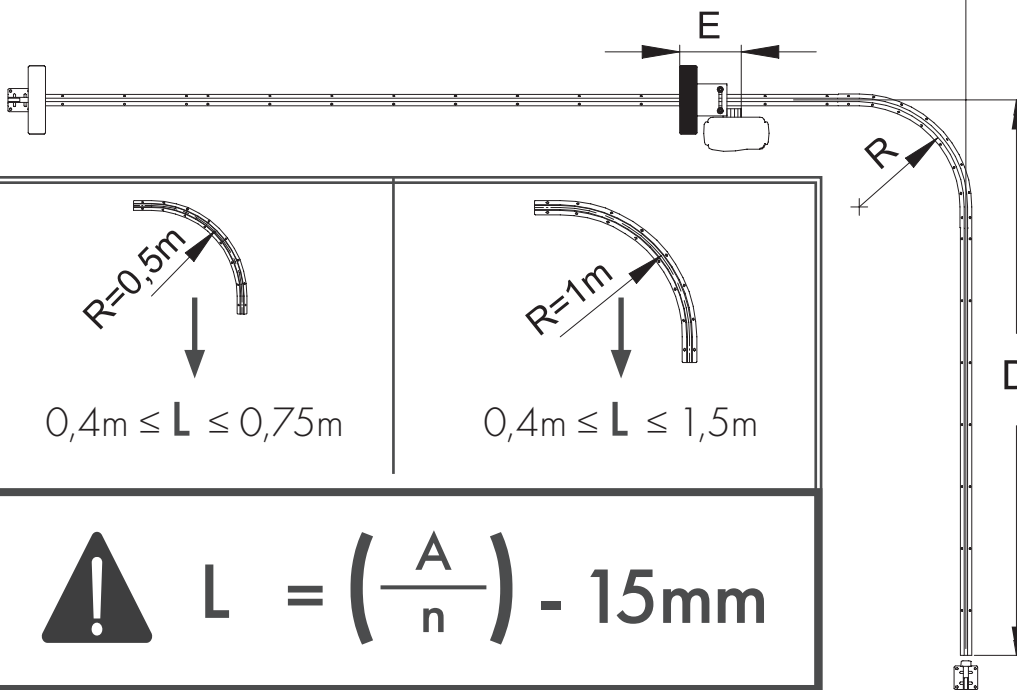

$G = L + E + R$   
 $D = A - E - 0,2m$

$G = L + E + R$   
 $D = A - E - 0,4m$



**Attenzione:**

Aumentare o diminuire **n** per ottenere valori **L** compatibili. Valori **G** min. sono ottenibili usando ante corte e rotaia  $R=0,5$  ( $L \sim 0,4m$  e  $E=0,35m$ )  
**D** dipende dai valori **A**, **L** e dal raggio **R** scelto

**Warning:**

Raise or lower **n** to obtain compatible **L** values. Use short leaves and curved rails  $R=0,5$  to obtain **G** values ( $L \sim 0,4m$  e  $E=0,35m$ )  
**D** depends on **A-L** values and on the radius **R** chosen

**LEGENDA**

- A** = apertura / opening
- G** = ingombro posteriore / amount of space behind the opening
- E** = distanza tra il perno del motore e la colonna / distance between the gate motor and column
- R** = raggio curva / radius of curve
- L** = lunghezza anta / leaf length
- D** = ingombro laterale della rotaia / lateral space for the rail
- T** = spessore anta / leaf thickness
- nt** = numero totale di ante / total quantity of leaves



ANTE DA REALIZZARE E ARTICOLI DA ORDINARE  
ITEMS TO ORDER TO REALISE YOUR GATE

Anta principale S1  
Main leaf S1

1 x

KA8103.050

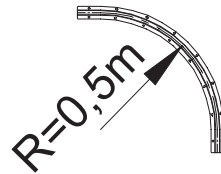

KA8103.100

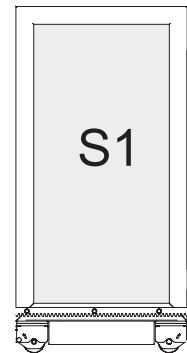
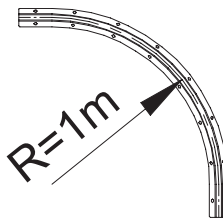

Anta secondaria  
Secondary leaf

KA8103.001 x numero di ante Sn  
number of leaves Sn

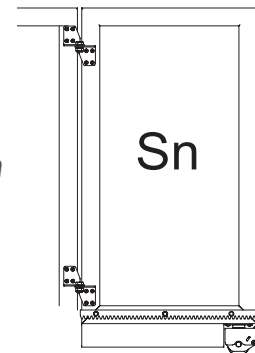



INFO TECNICHE  
TECHNICAL INFO

1. Importante: la superficie di lavoro per il cancello sezionale deve essere in piano, priva di dossi o avvallamenti
2. Per cancelli motorizzati è importante fare attenzione al posizionamento, al taglio ed alle misure massime della cremagliera ( vedi fig. 7)
3. Per cancelli motorizzati prevedere partenze ed arresti lenti. Velocità max= 0,18m/s

1. Important: the gate working surface must be flat, without bumps or hollows
2. For motorised gates it is important to pay attention to the rack's cut, the positioning and the maximum measurements
3. For motorised gates provide slow starting points and soft stops, with a maximum speed of = 0,18 m/s

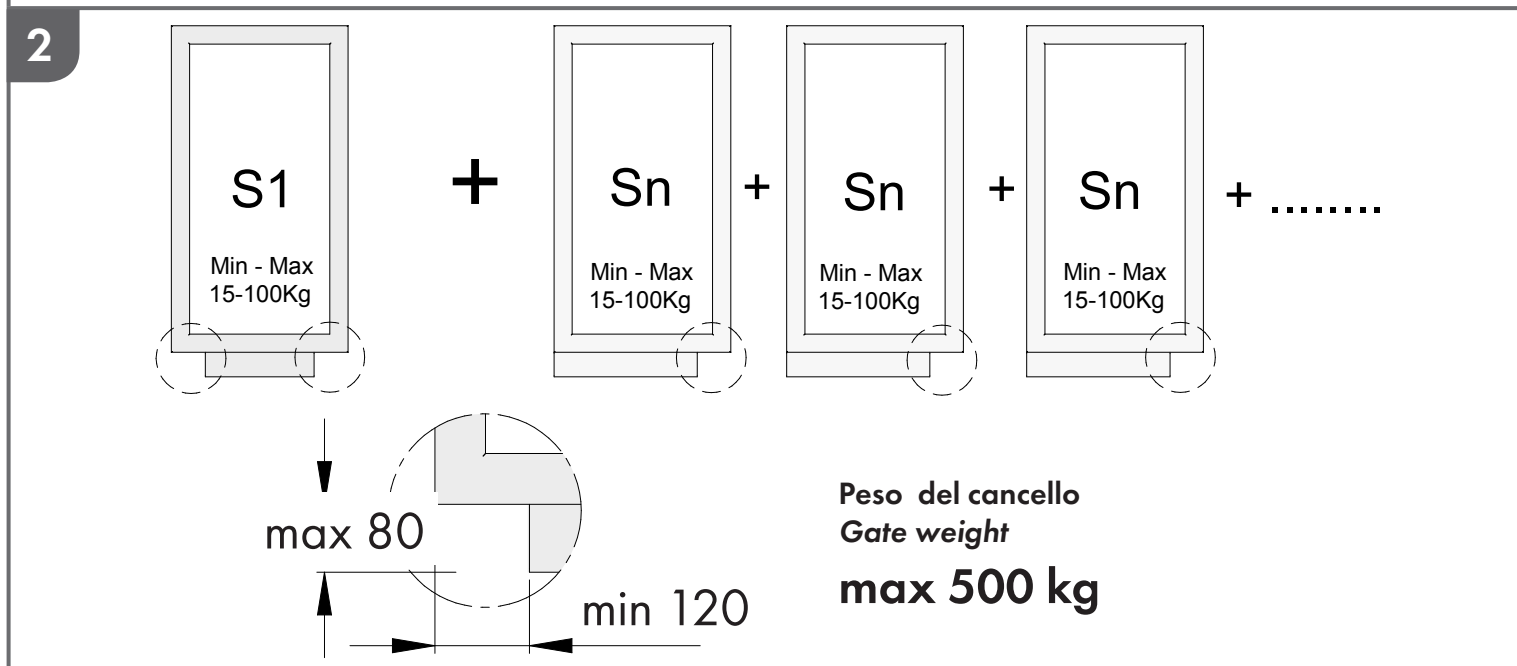
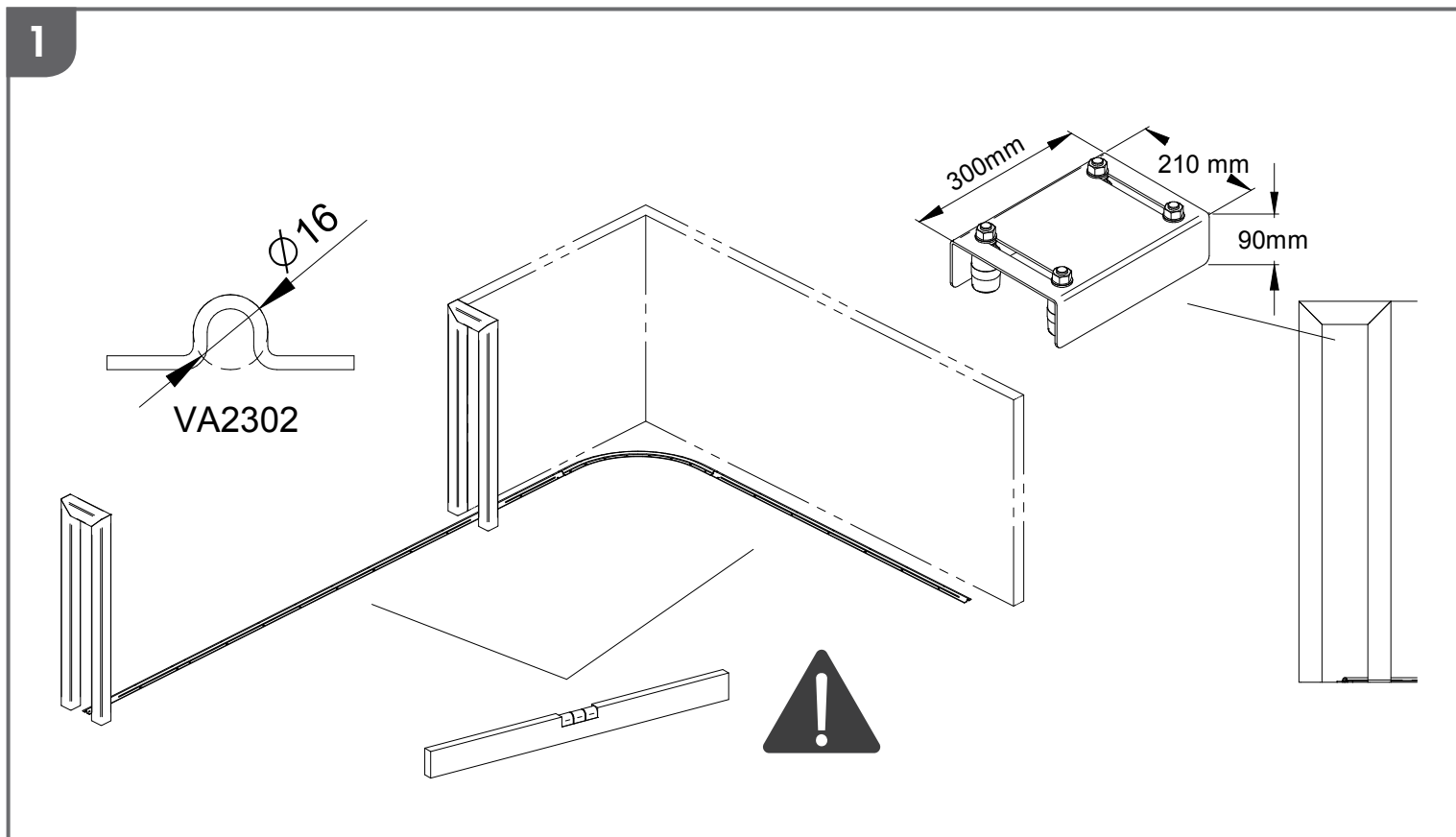



3

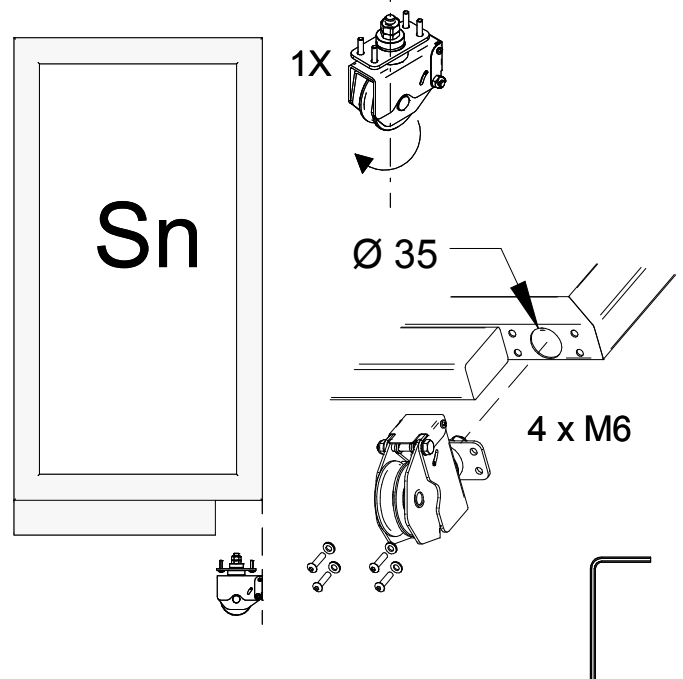
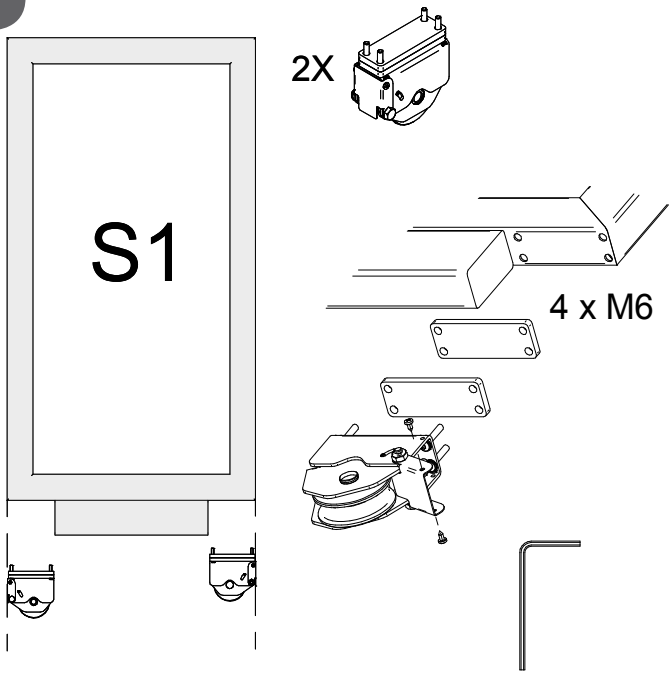

4

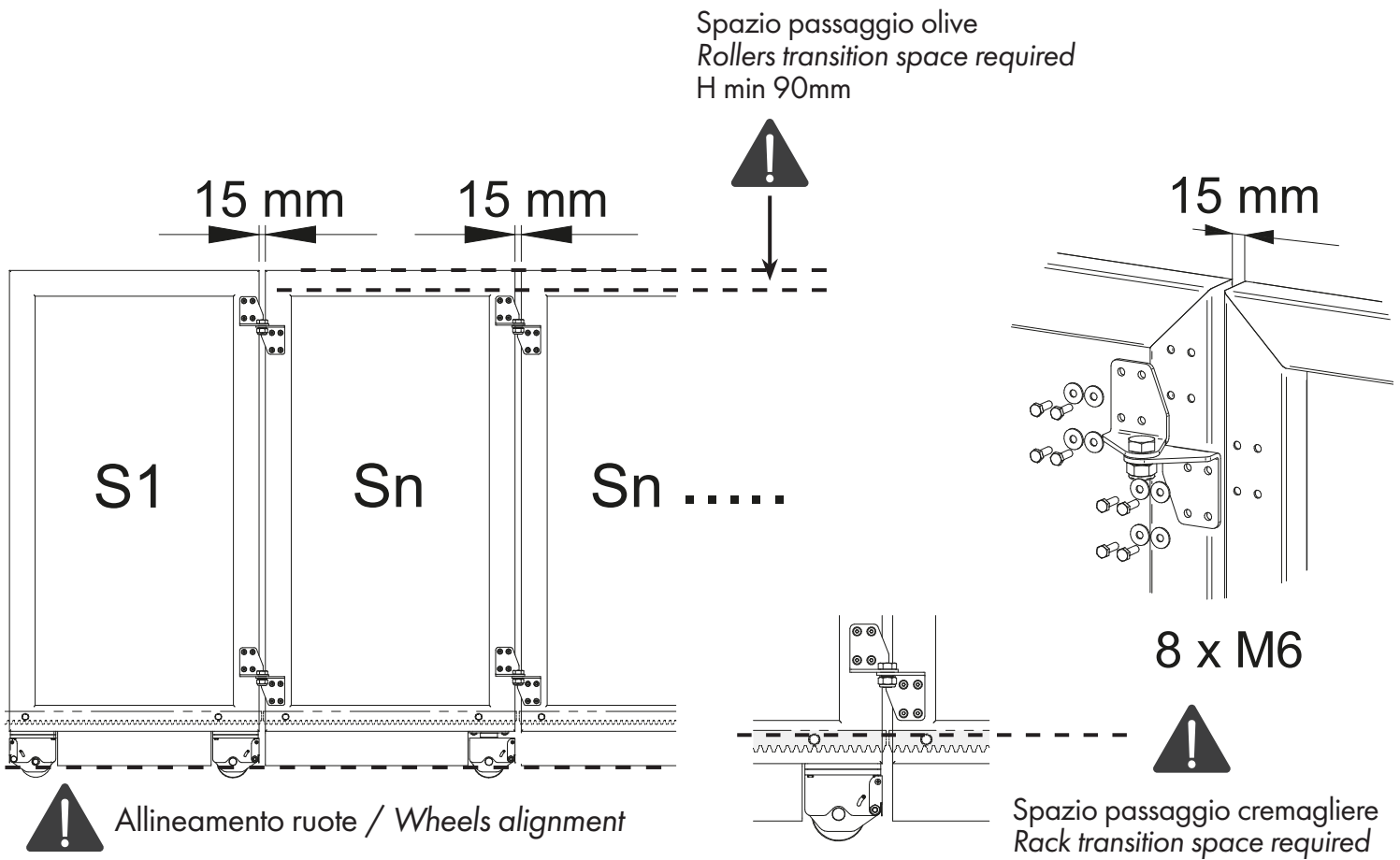



5

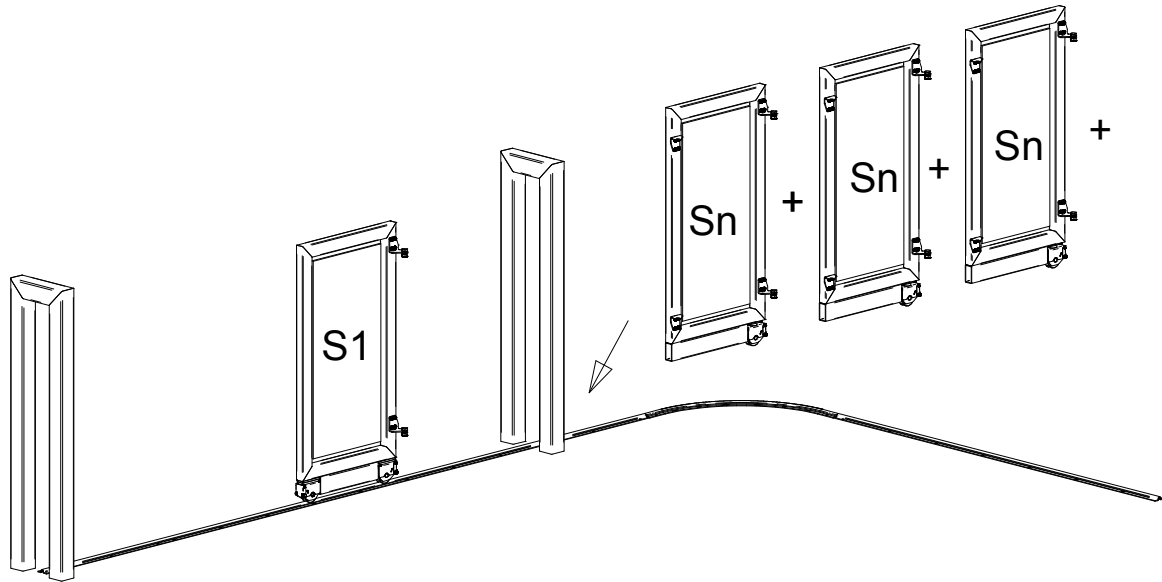

6

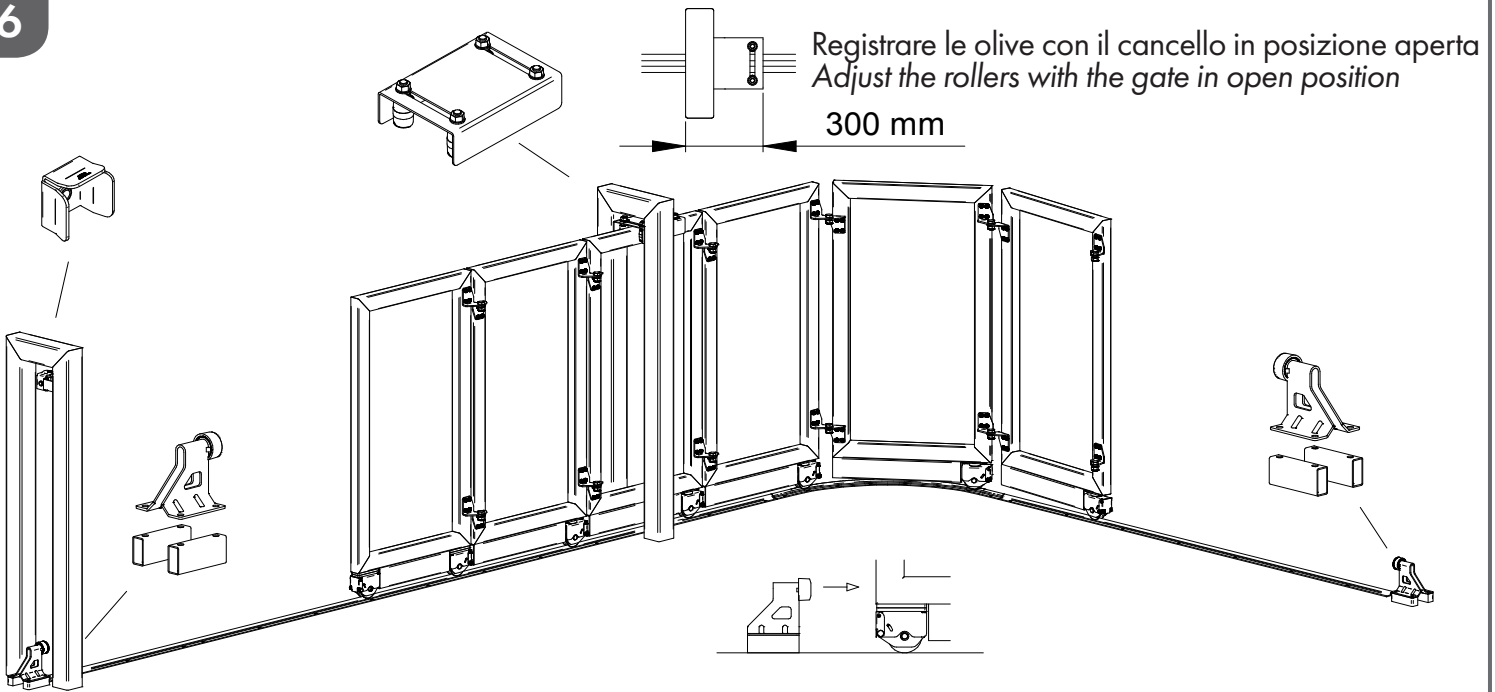

7

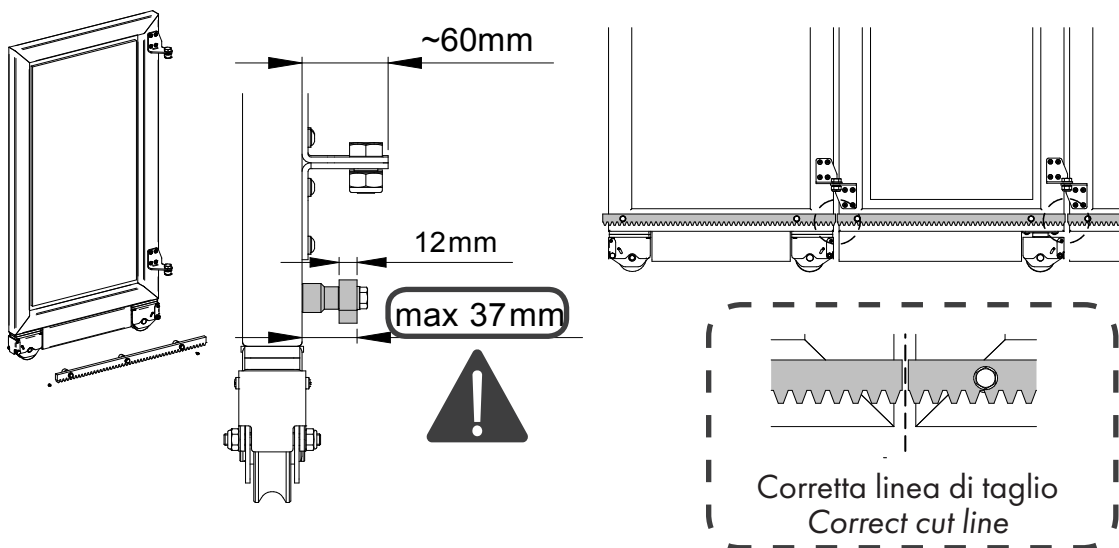



8



--- Zona di particolare rischio

Necessarie protezioni fisiche ed elettroniche

--- Dangerous area

Physical and electronic protections required

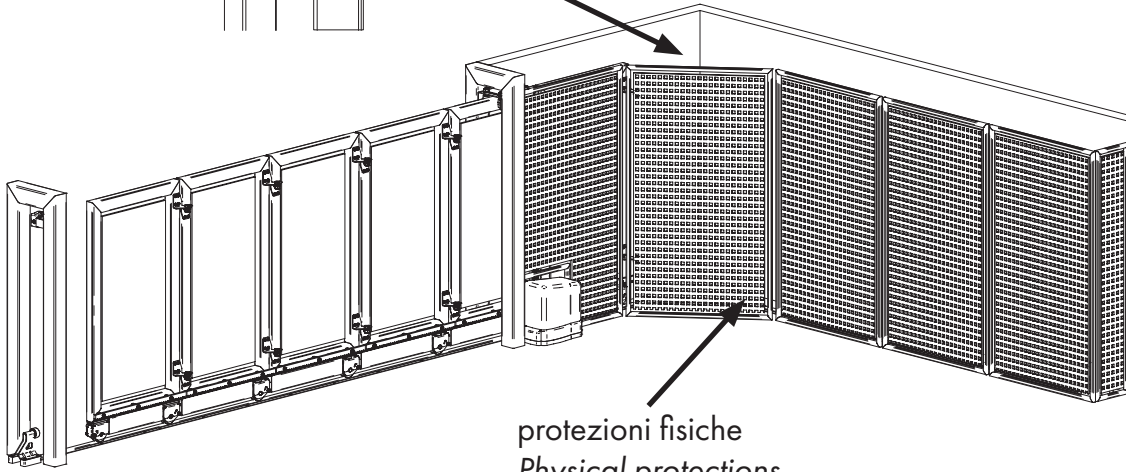
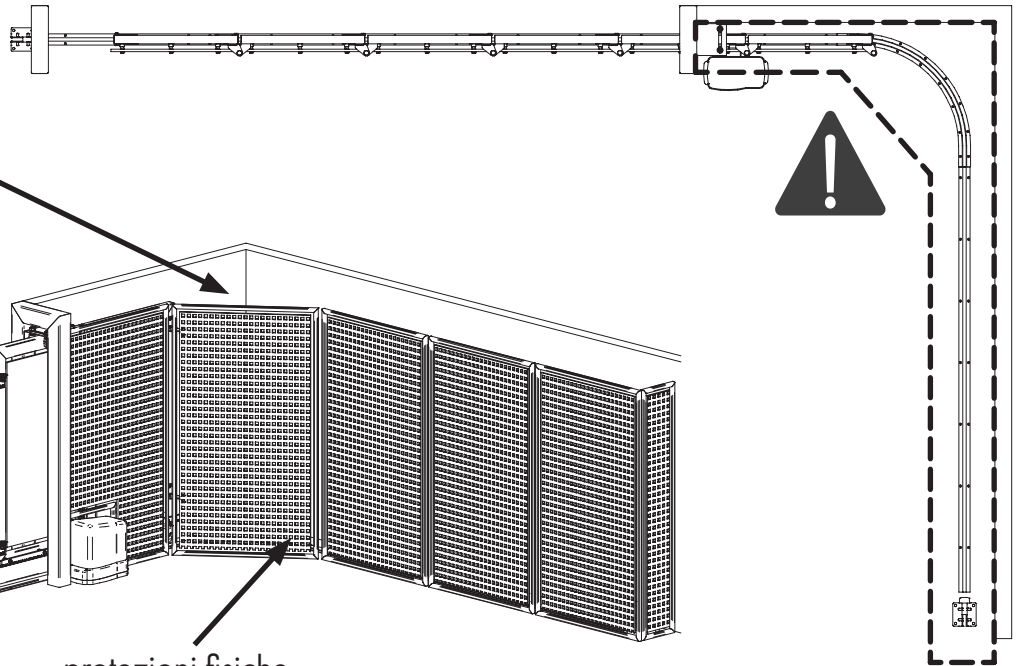
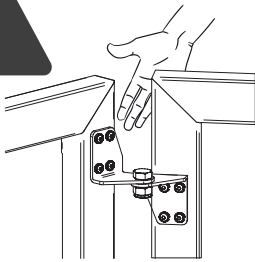

protezioni fisiche  
Physical protections

## MANUTENZIONE MAINTENANCE

1. Eseguire le verifiche di funzionamento manuale a fine installazione; controllare periodicamente che il sistema sia funzionante, privo di allentamenti e lubrificato (consigliato ogni 3 mesi e massimo 8000 cicli)
2. In caso di malfunzionamenti dovuti ad usura o urti accidentali, assicurarsi che tutti i componenti atti al sostegno del cancello e alla sua manutenzione siano integri. Se necessario procedere alla sostituzione.
3. FAC garantisce il corretto funzionamento del sistema esclusivamente con l'utilizzo di ricambi originali

**Attenzione:** Gli accessori compresi nei kit e l'installazione proposta fanno riferimento ad un esempio standard. Una installazione non conforme alla procedura illustrata e/o l'omissione delle corrette manutenzione potrebbero causare malfunzionamenti, compromettendo la sicurezza di persone e cose adiacenti. Verificare che gli accessori siano idonei all'opera specifica e dotarla dei necessari dispositivi di sicurezza previsti dalle normative vigenti.

**Per ulteriori informazioni scrivici a : [info@facsr.com](mailto:info@facsr.com)**

1. Perform all functioning inspections manually at the end of the installation; periodically check that the system is functioning, well lubricated and does not have any loosening. (We suggest a full examination every 3 months or after 8000 cycles).
2. In case of malfunctions due to wear or accidental impacts, make sure that all components apt to support the gate and its maintenance are intact. If necessary, proceed with substitution.
3. FAC ensures the system correct functioning only using original spare parts.

**Attention:** The kit included accessories and the proposed installation make reference to a standard example. An installation not in accordance with the illustrated procedure and the omission of the correct maintenance might compromise nearby things and people's security. Make sure that all accessories suit the specific work and make sure to use the necessary safety devices provided by current regulations.

**For more information: [info@facsr.com](mailto:info@facsr.com)**