



**MOTIONS**

OPENING SOLUTIONS

---

TELESCOPIC GATE



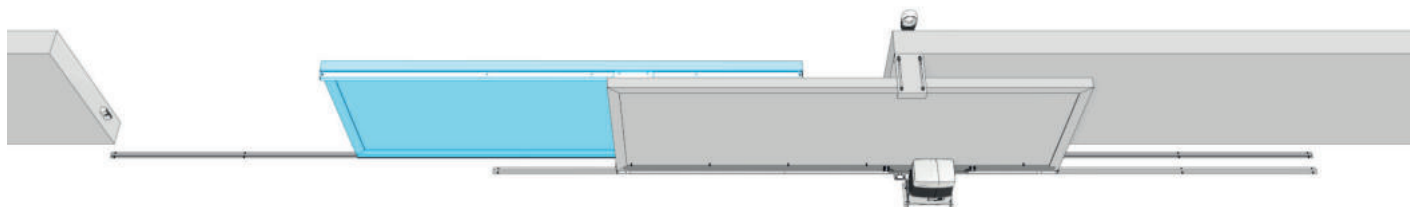

> **BOTTOM MOUNTING:** Setting the first leaf

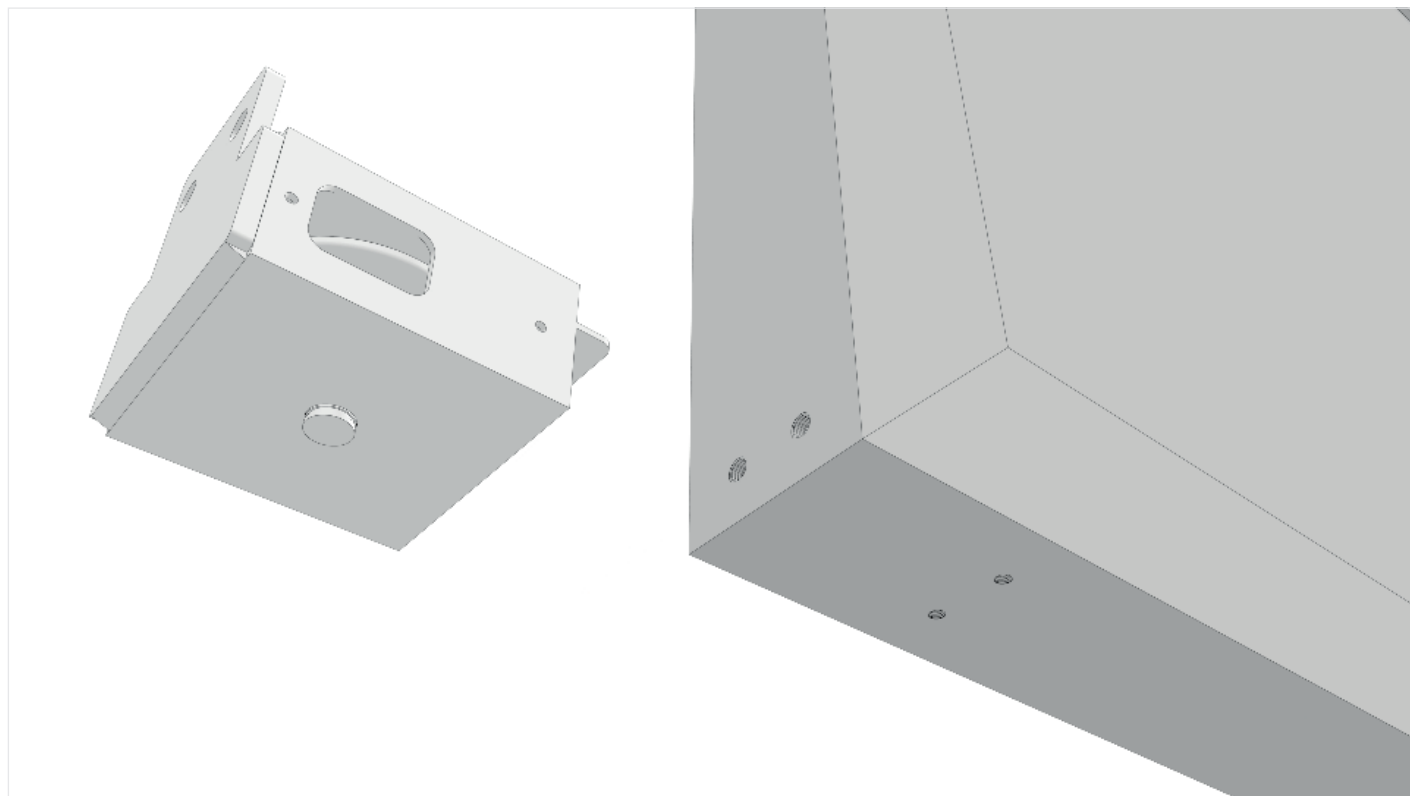

Fix or weld onto the two sides of the gate the boxes with the pulley.

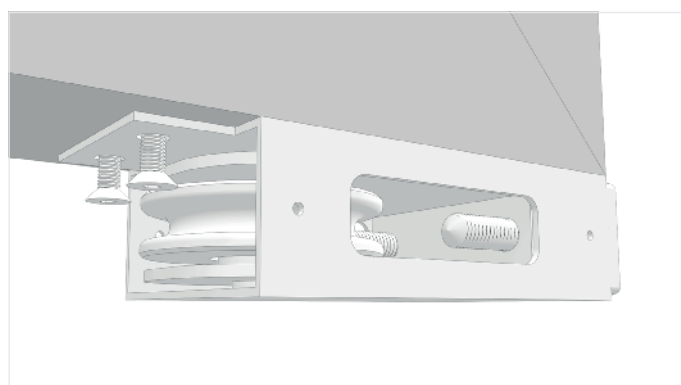
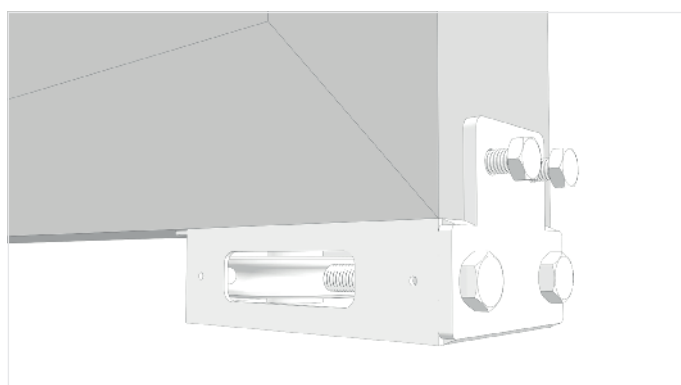
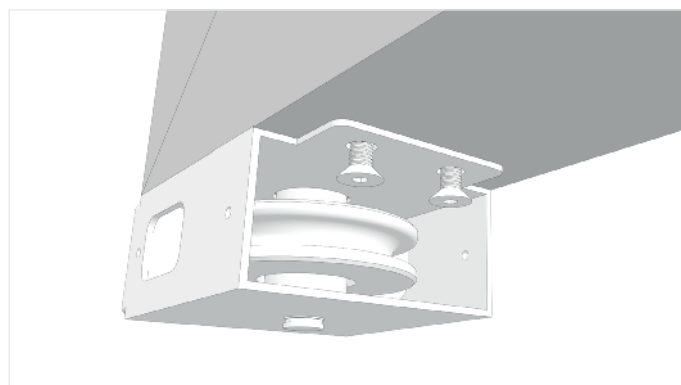
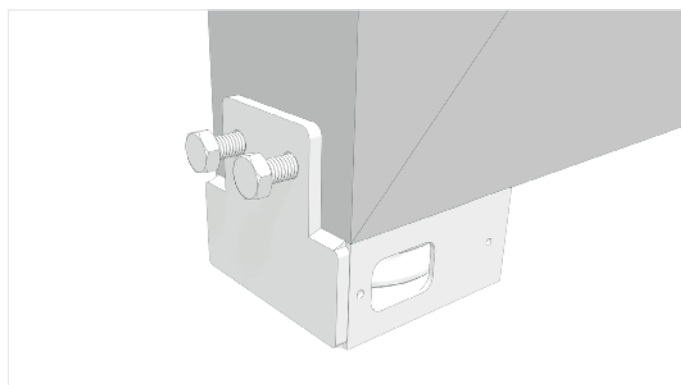

Fix the wheels. We recommend the use of our dedicated wheels 109.120T or 111.120T.  
In case of use of any standar wheel, diameter must be at least 120 mm or more.

**Make sure the wheels do not interfere with the cable movement.**

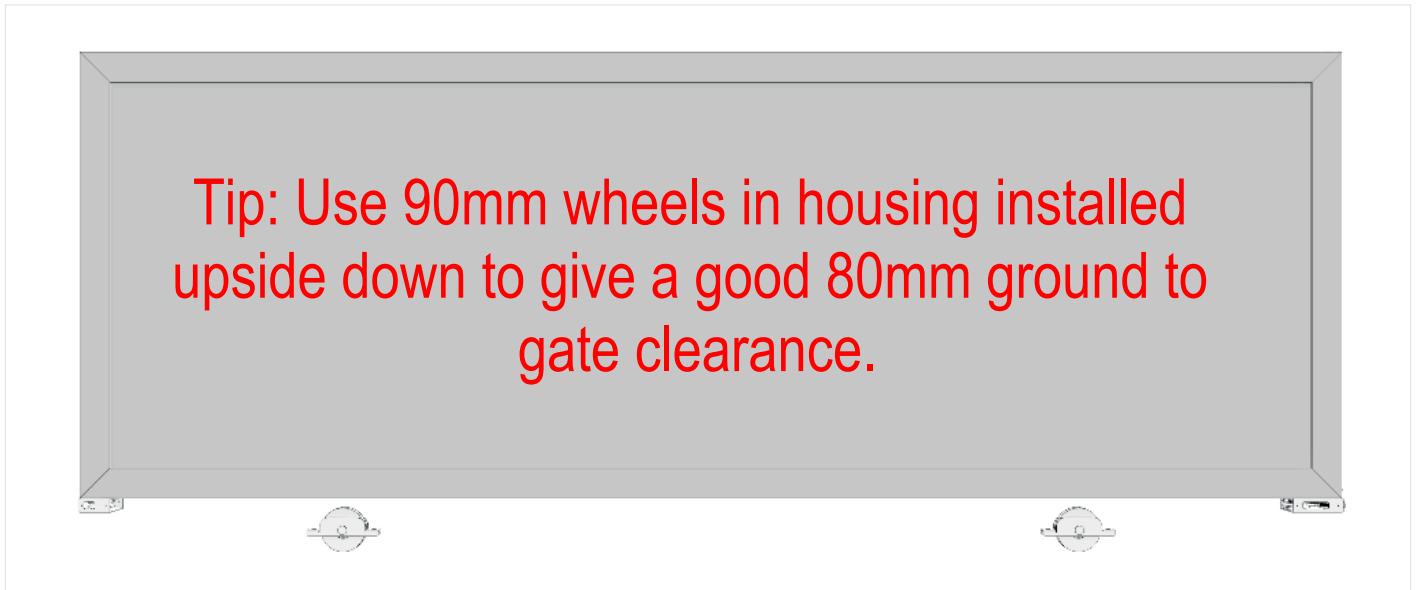

Fix the cover with screws or rivets.

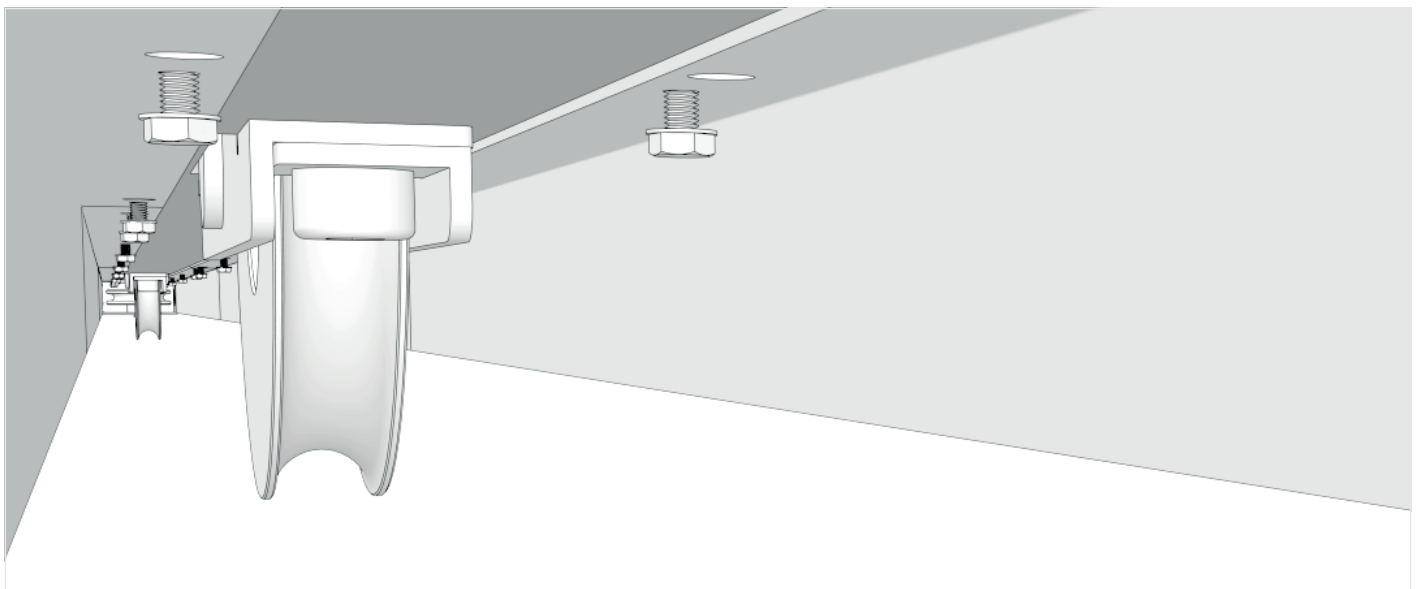
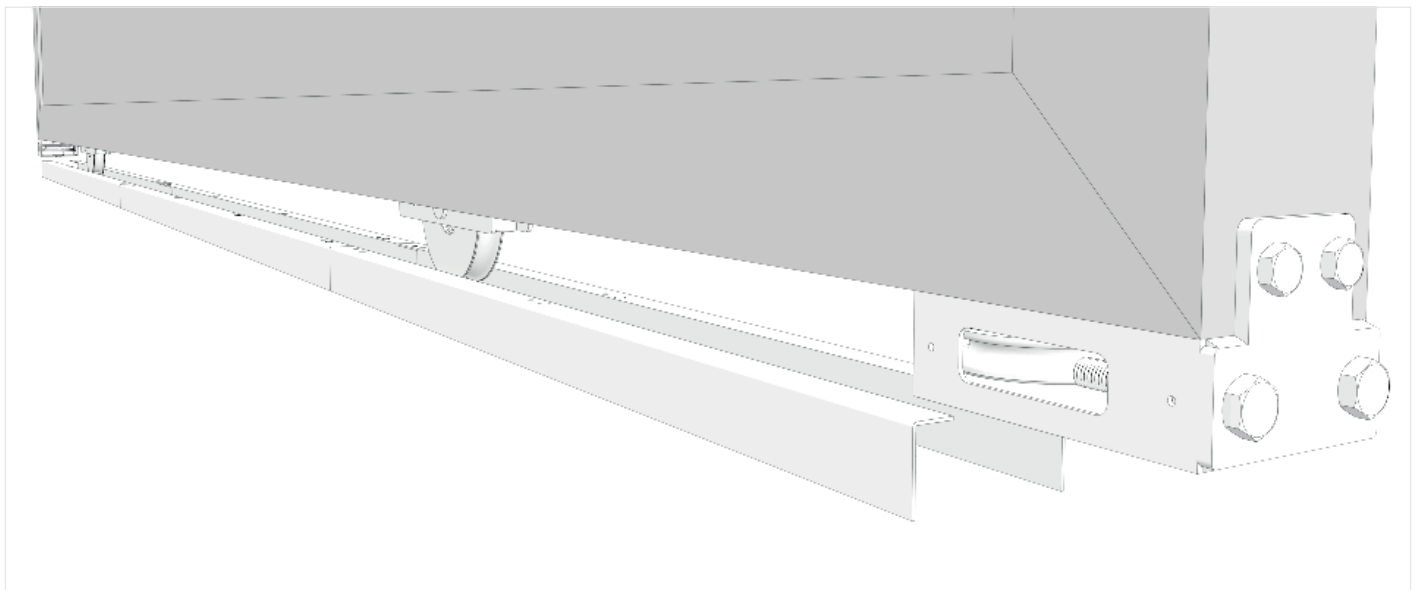

Fix the upper guide to the first leaf.

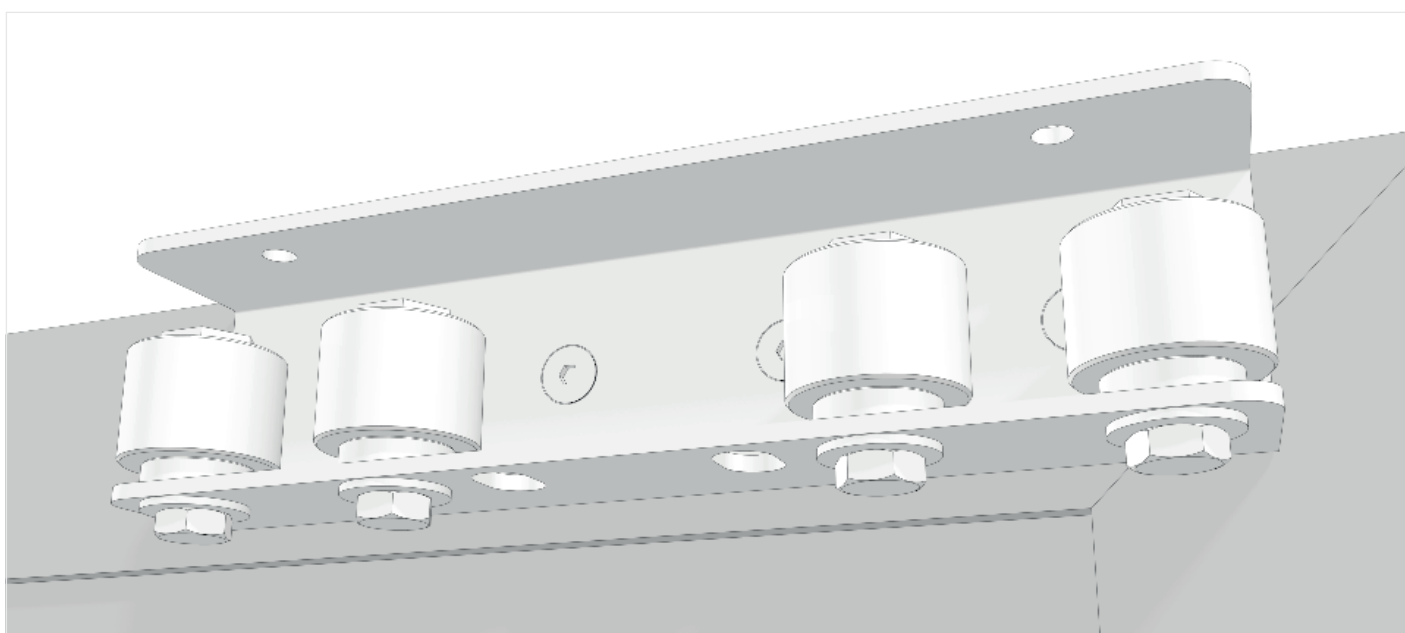
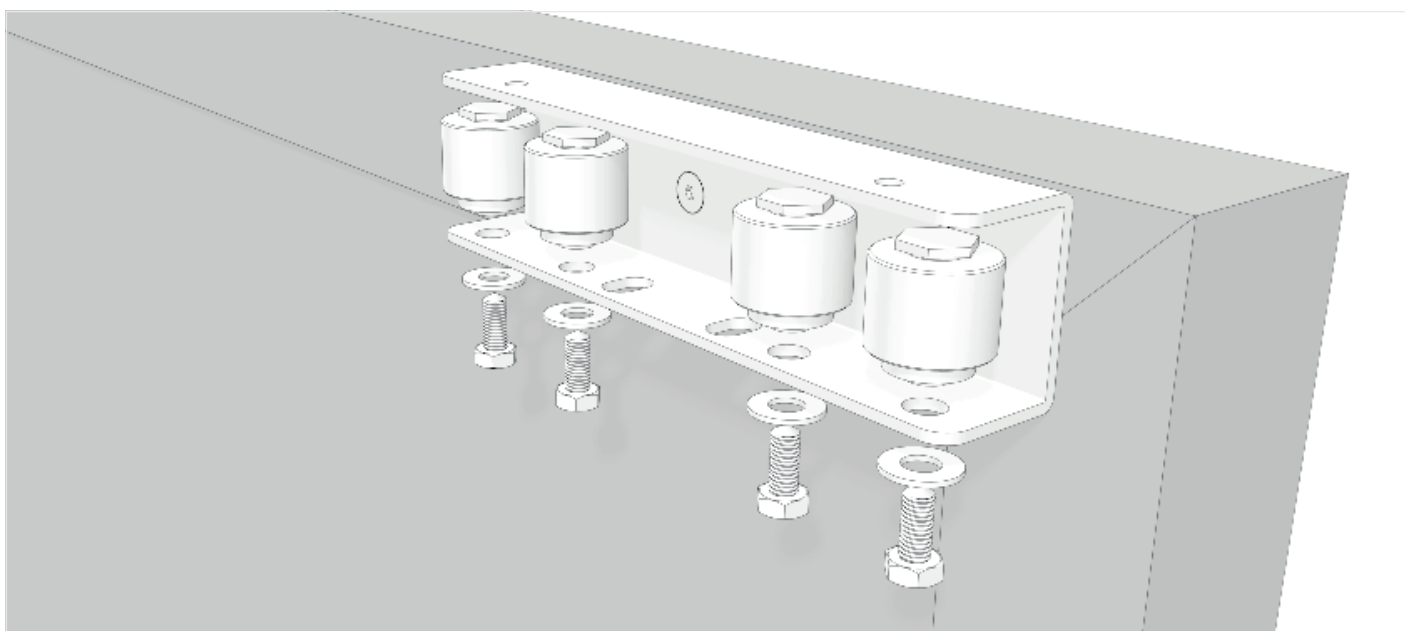
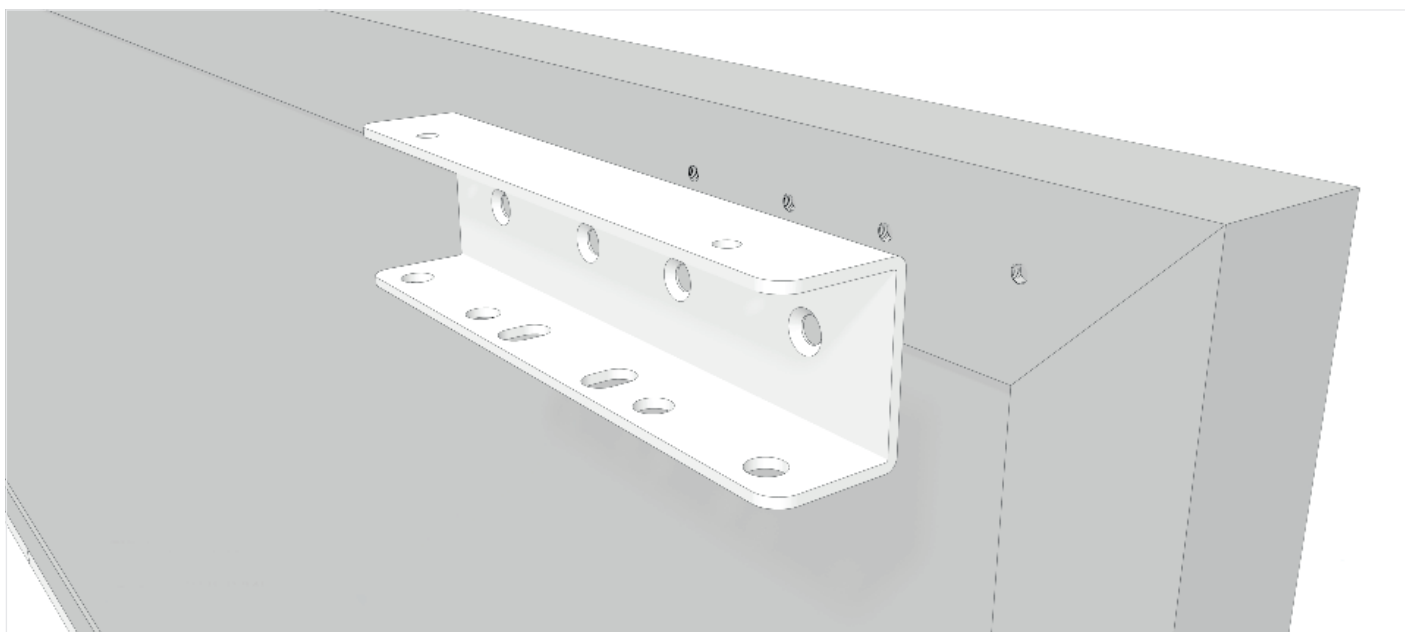

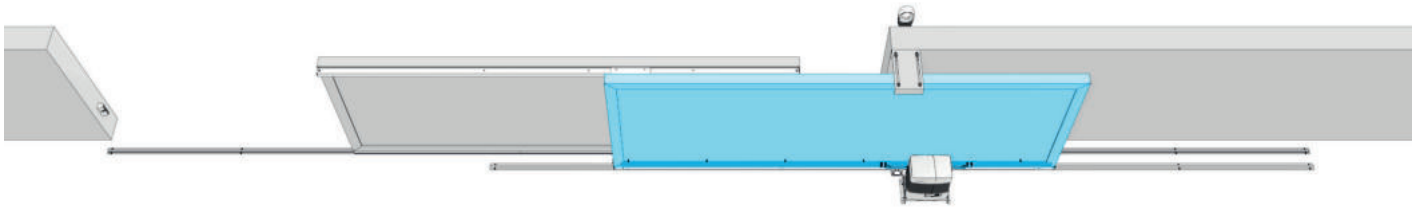

> **BOTTOM MOUNTING:** Setting the second leaf

Fix or weld the guiding profile to the second leaf.

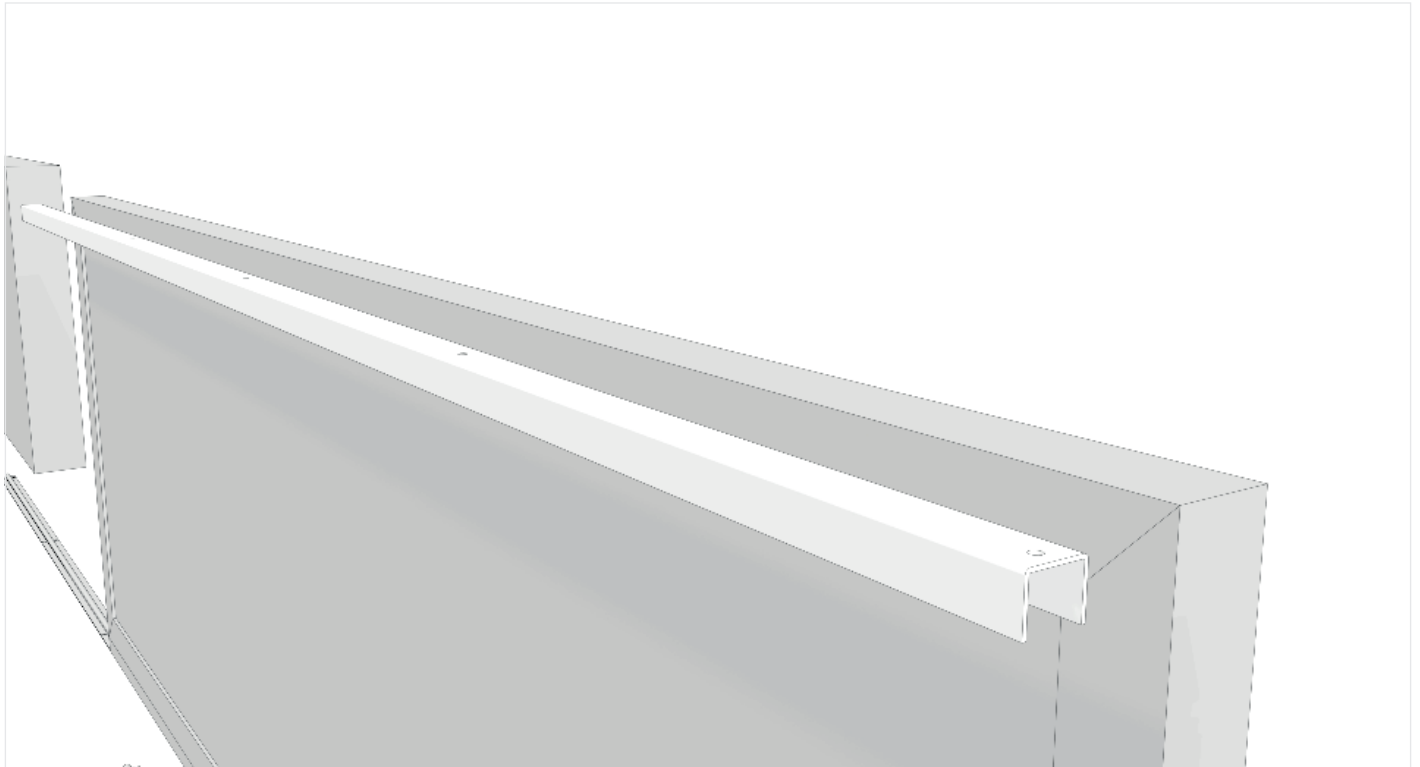

Set the bracket onto the back side of the second leaf.

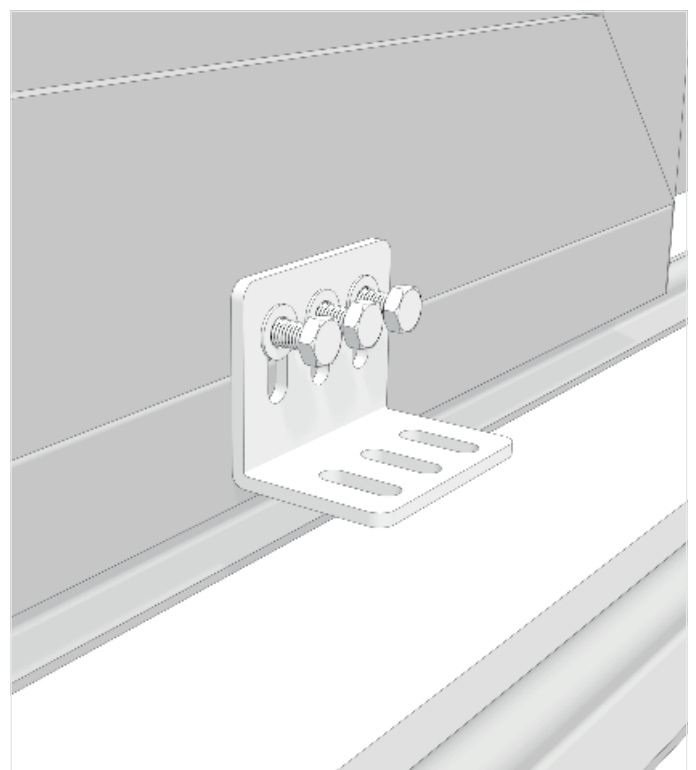
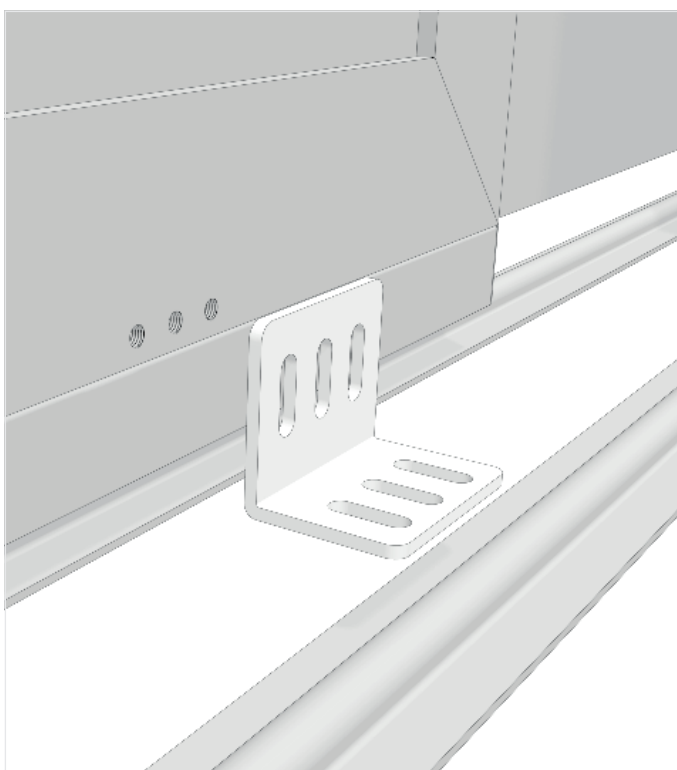

Fix the cover caps of the profile.

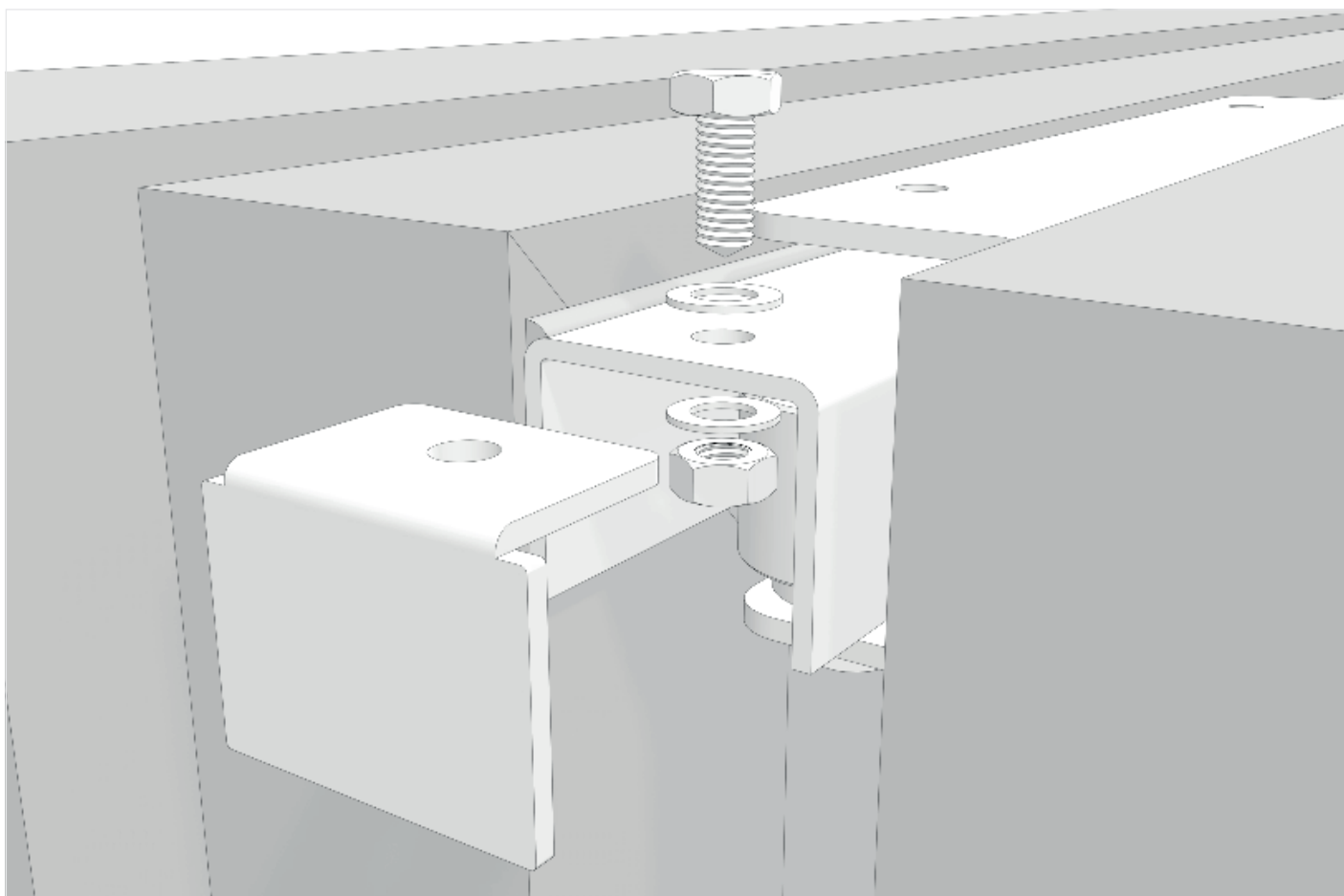

Loose the adjustable pulley.

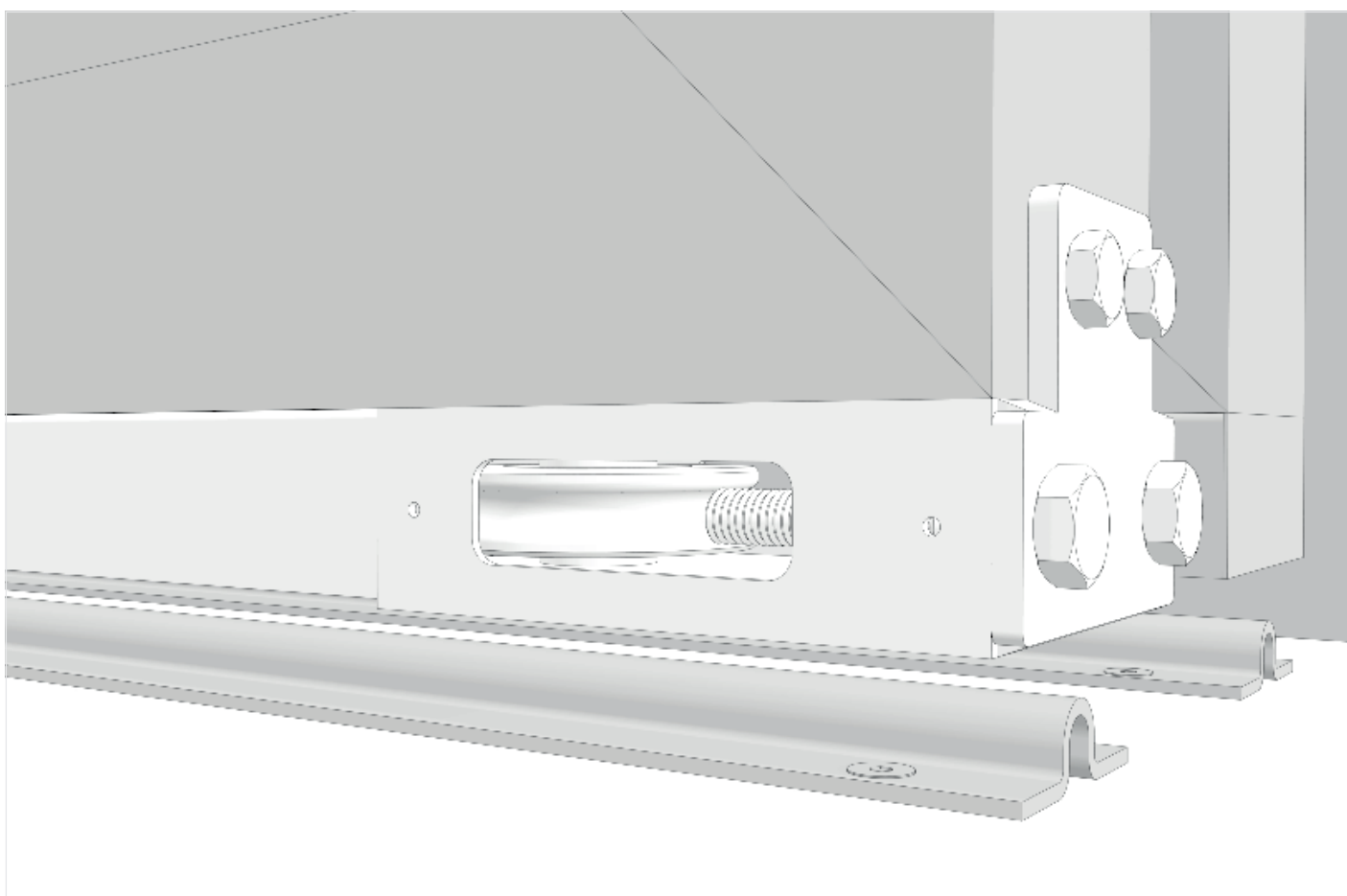

Set the cable through the pulley boxes.

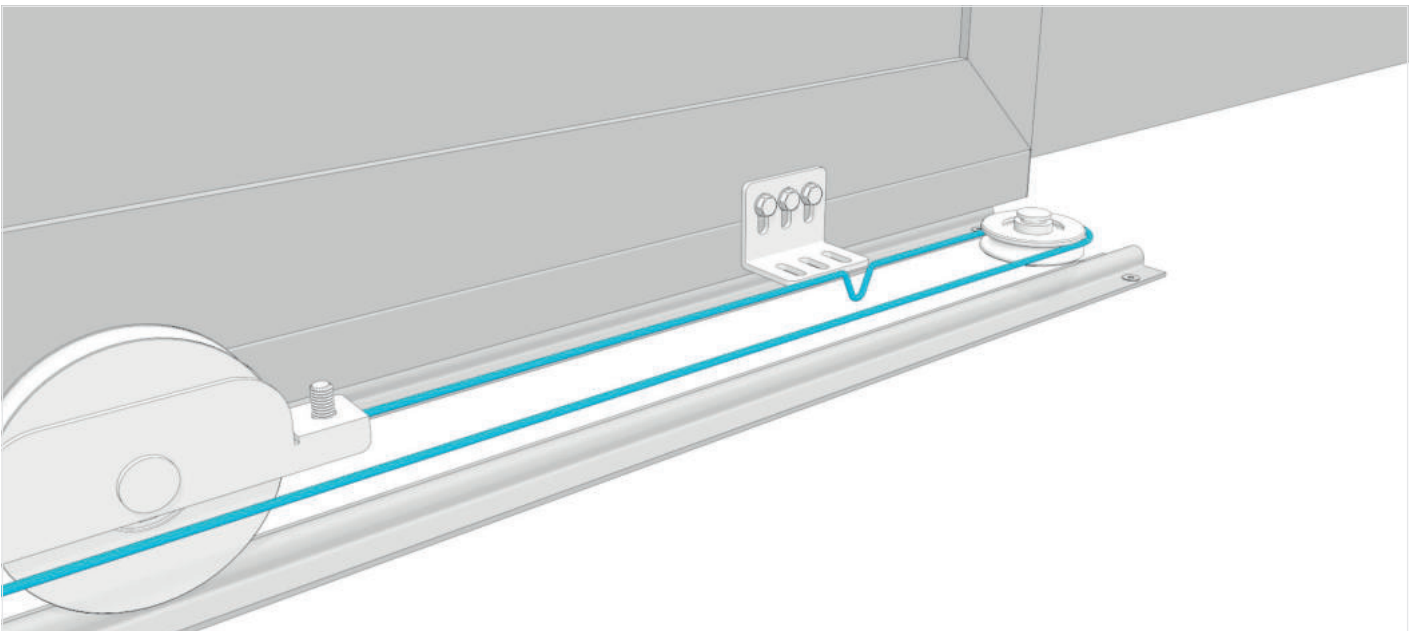
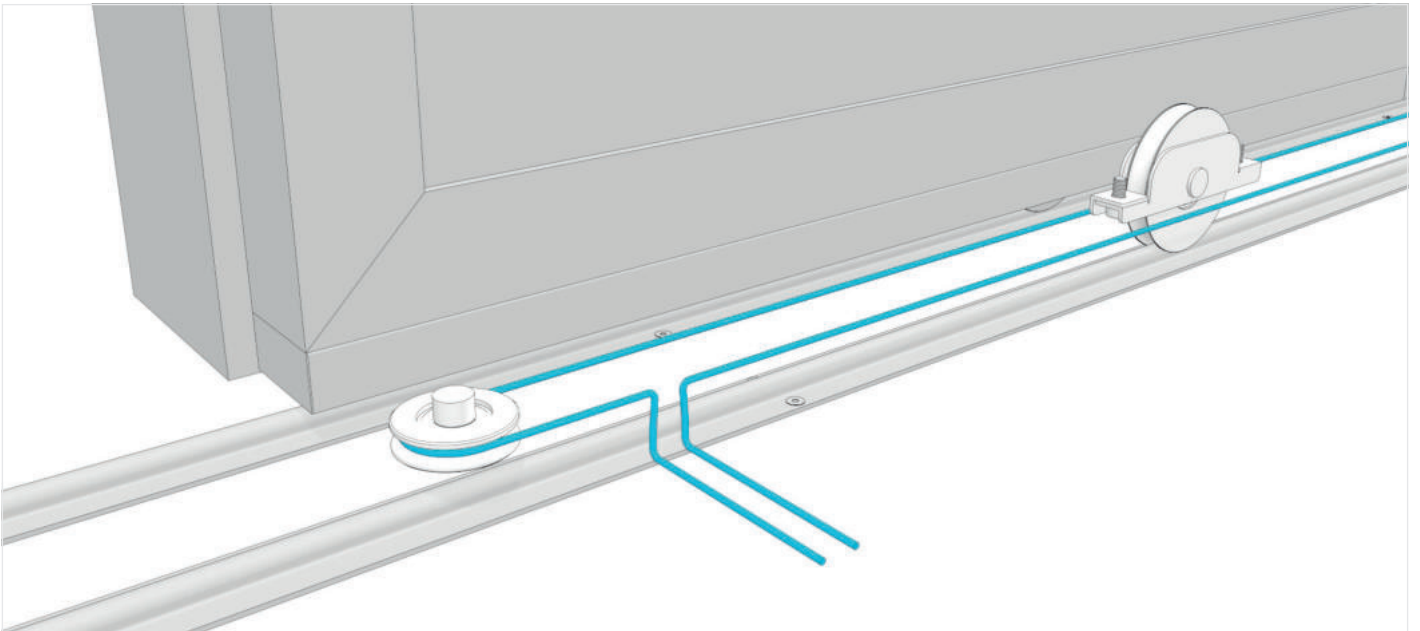
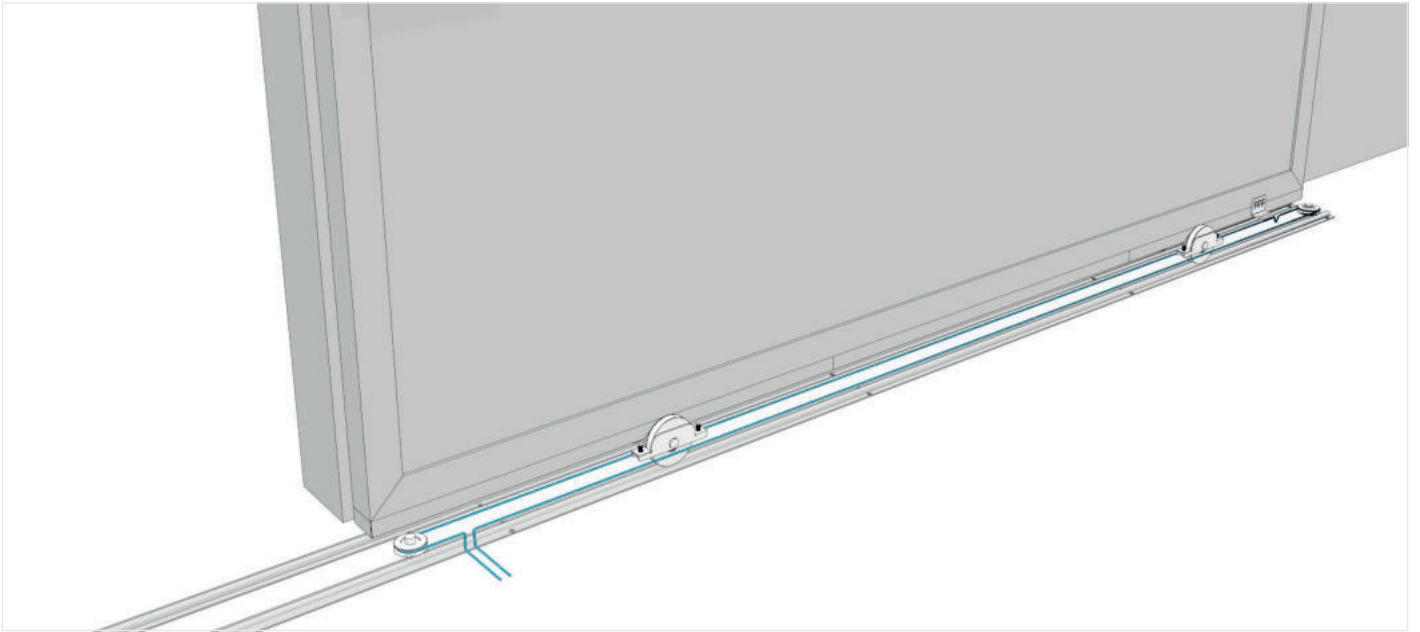



Fix the rear bracket to move the second leaf.

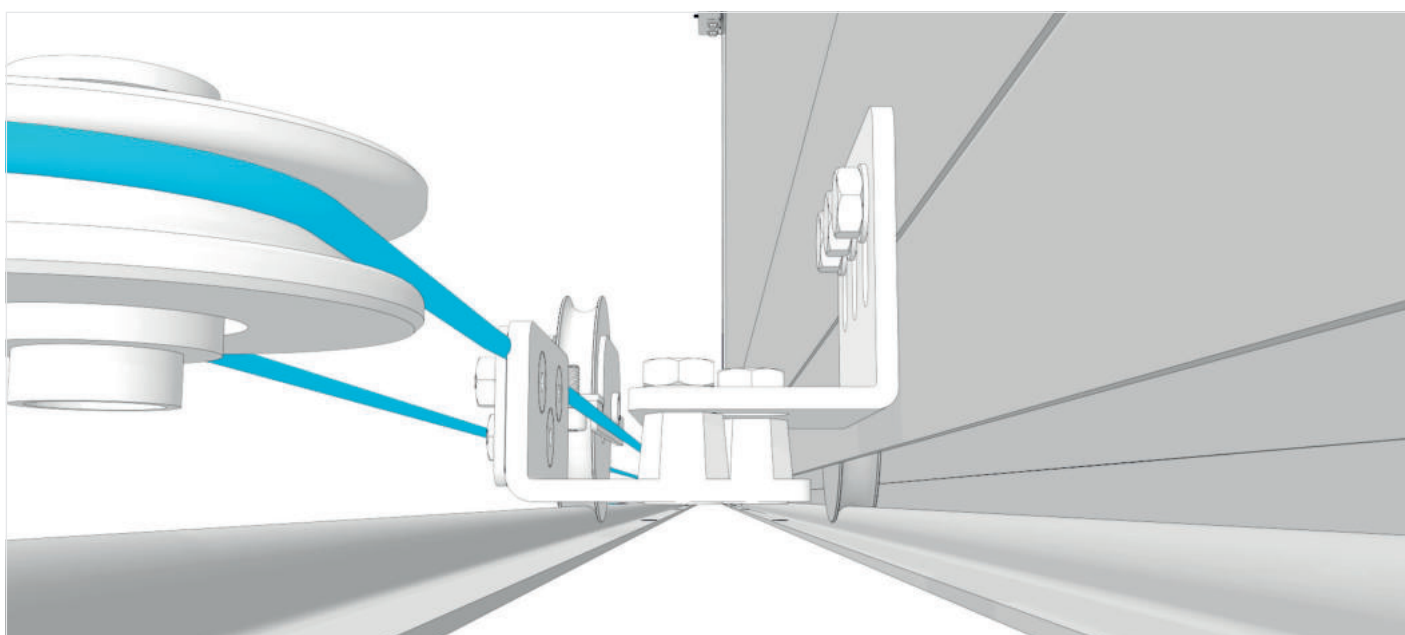
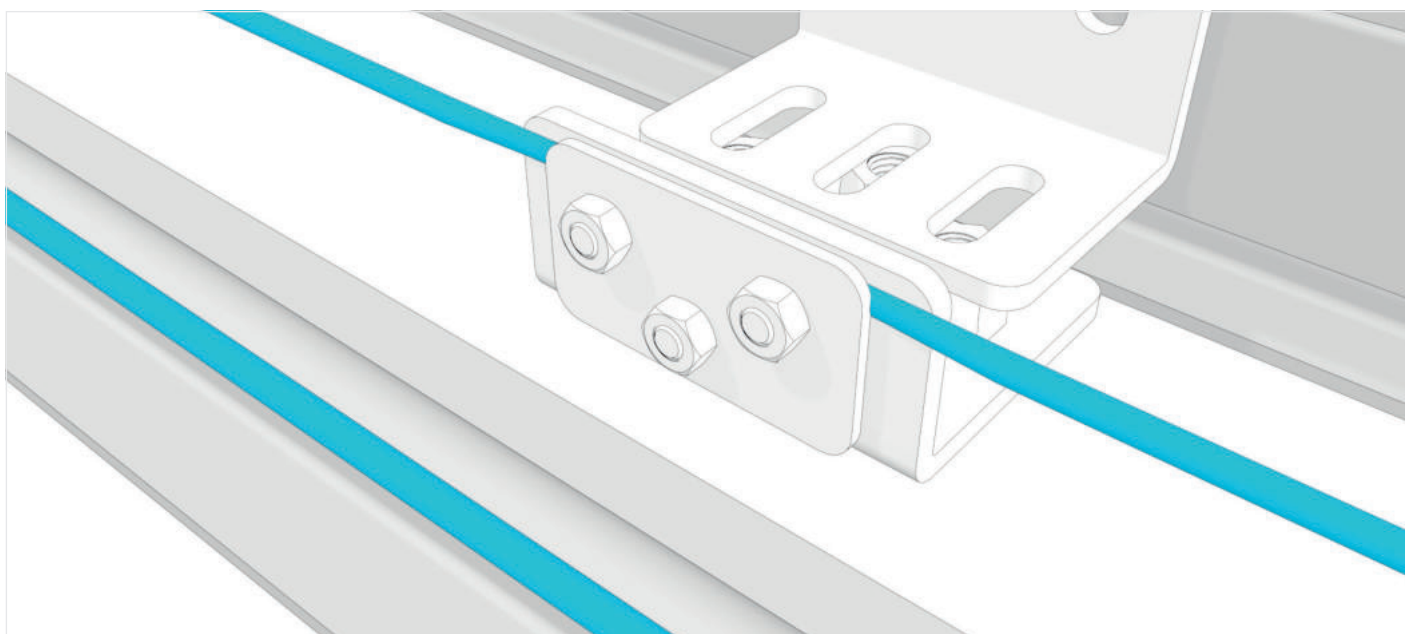
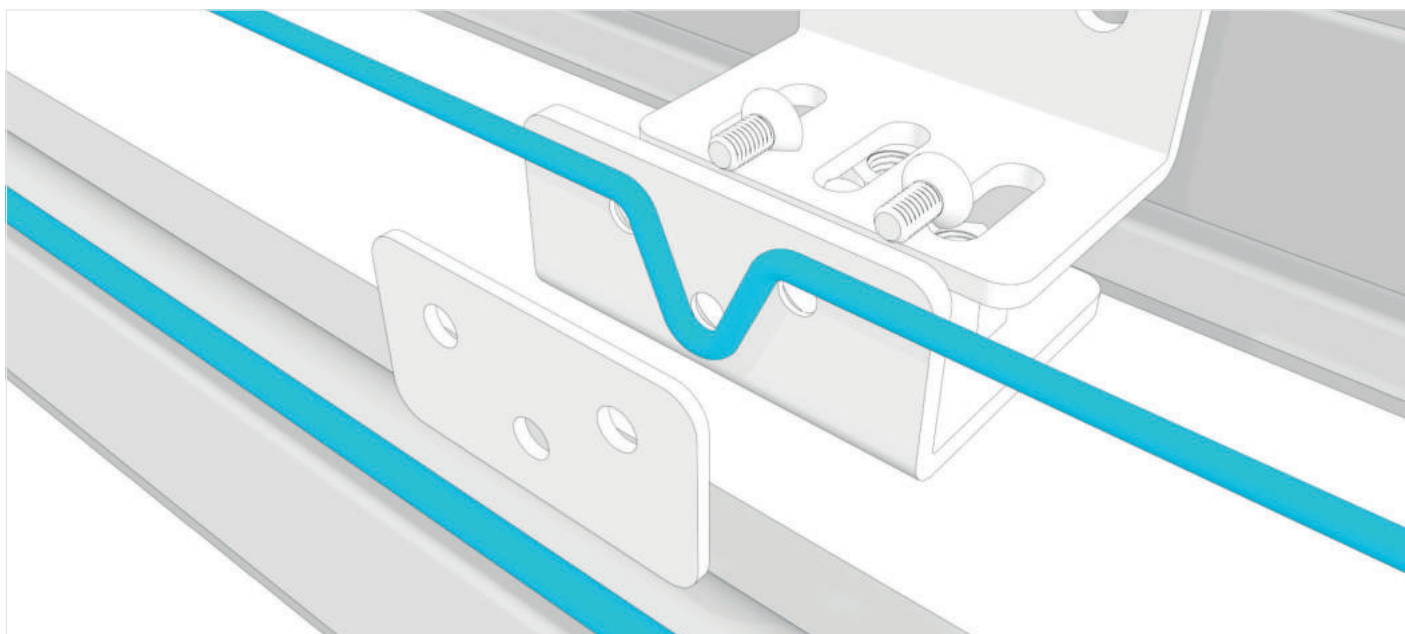

Adjust the cable length and fix the bracket onto the floor.

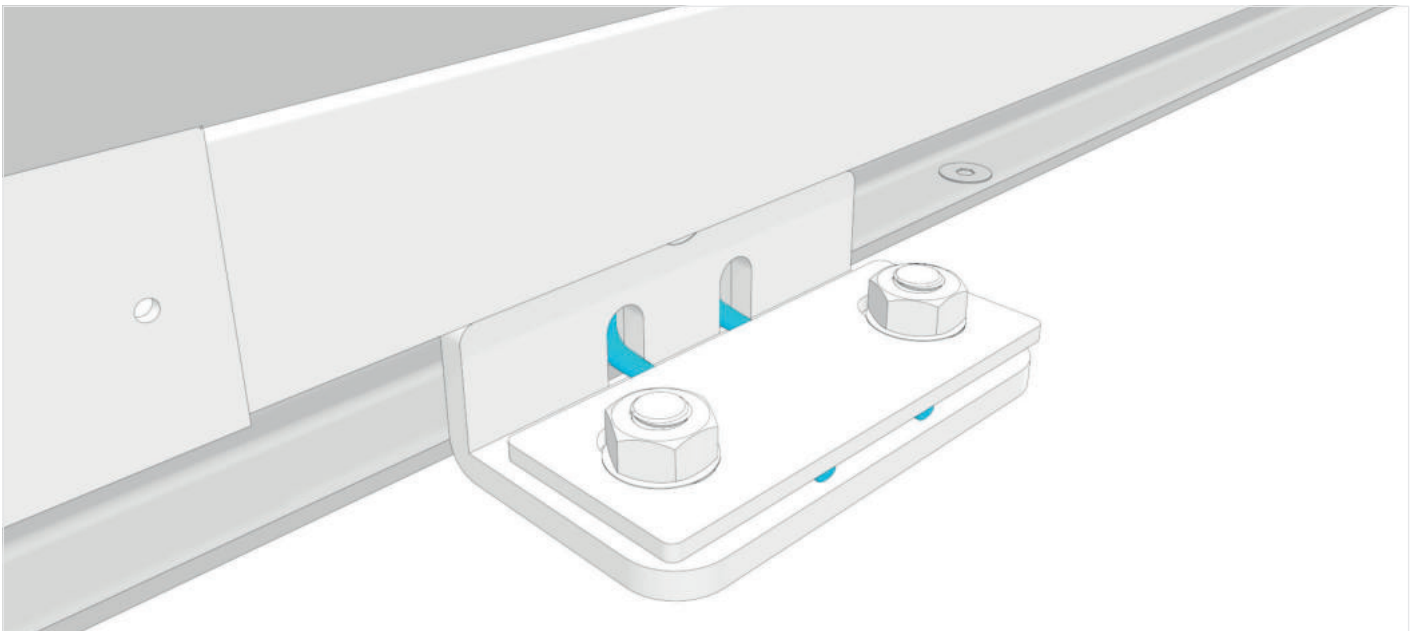
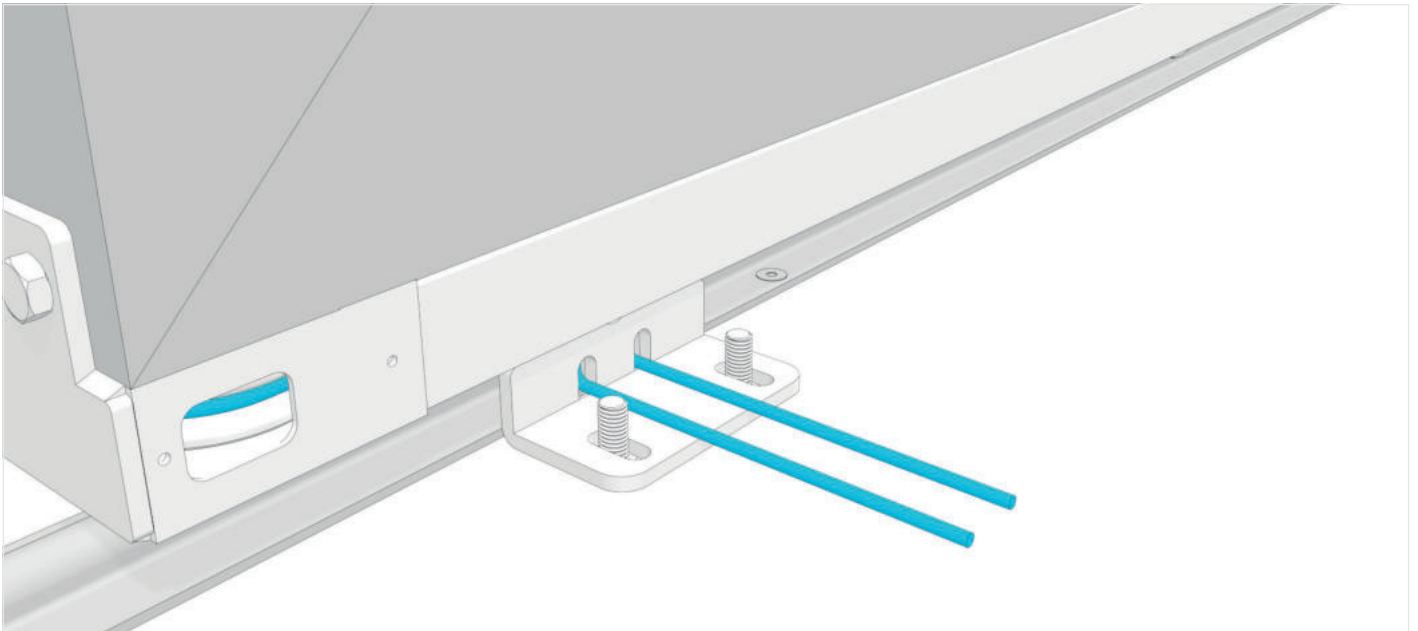
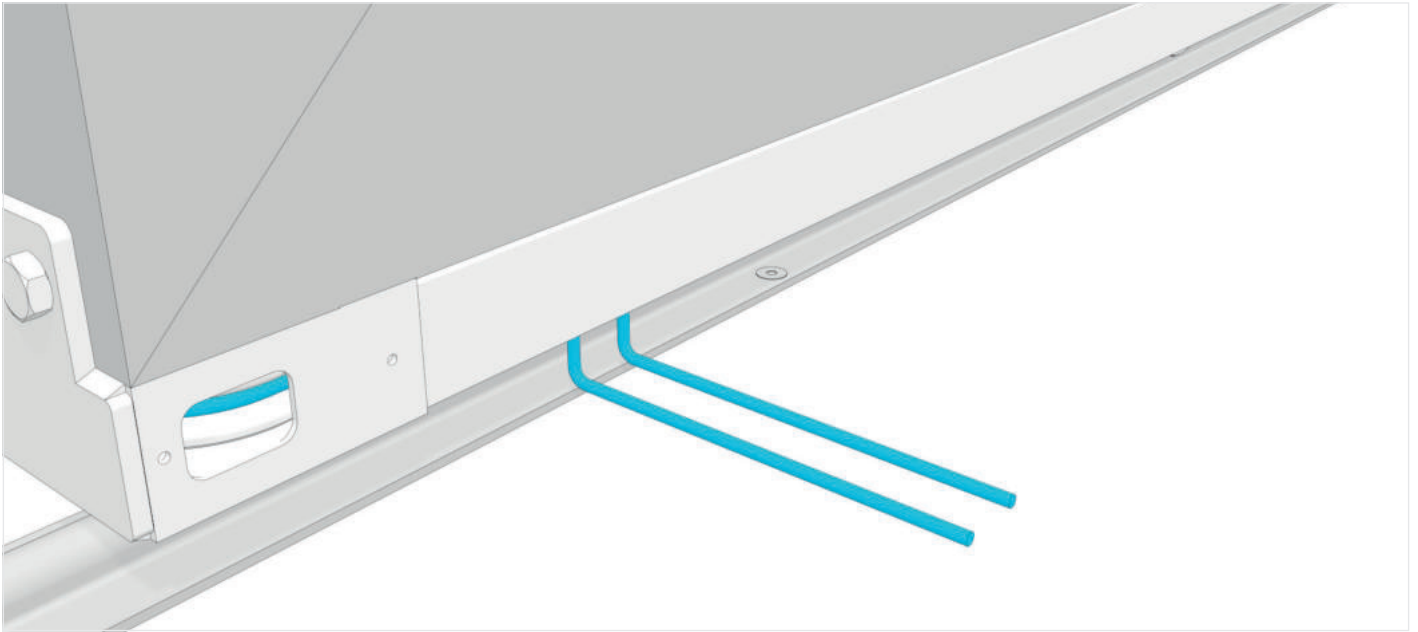

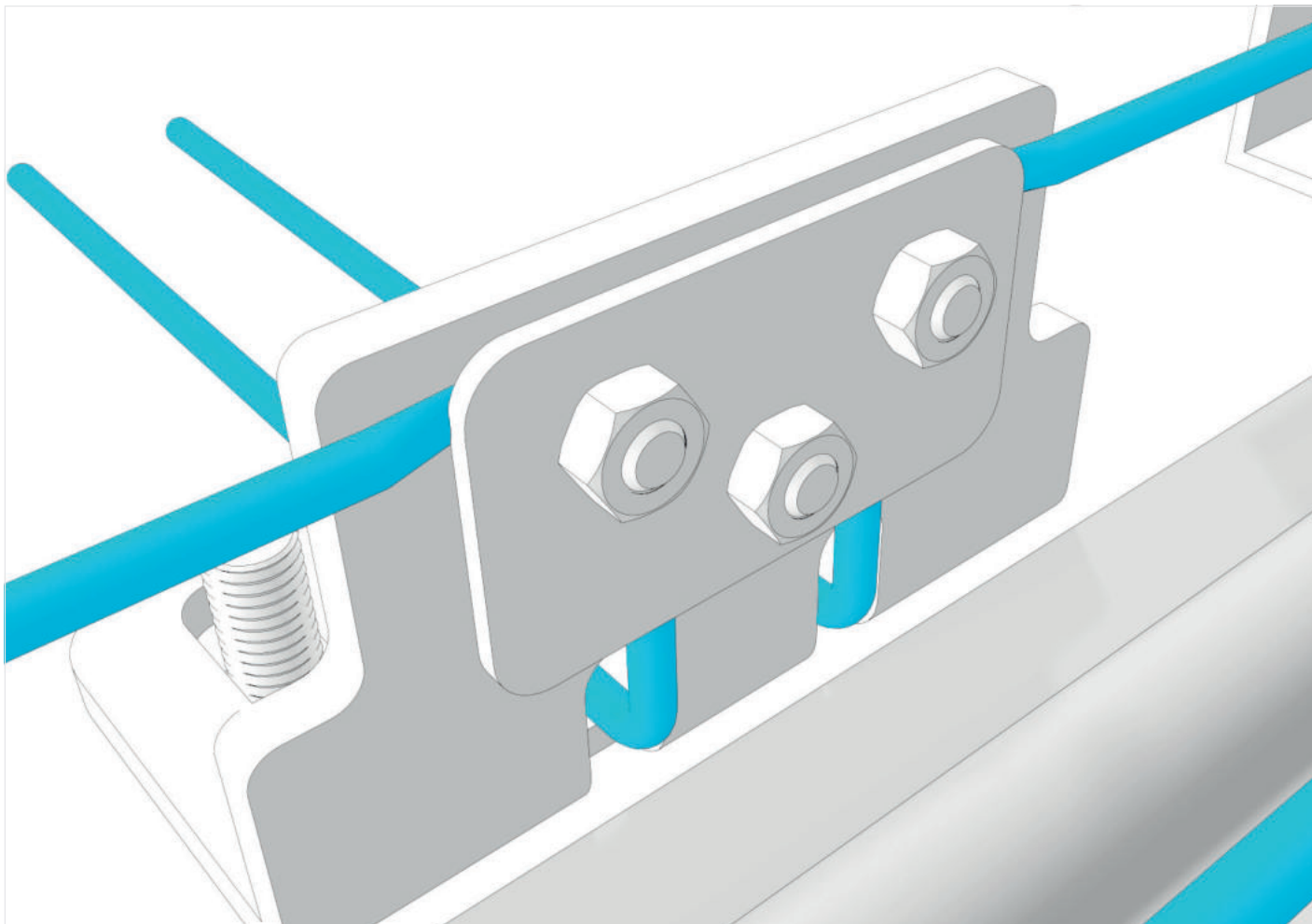
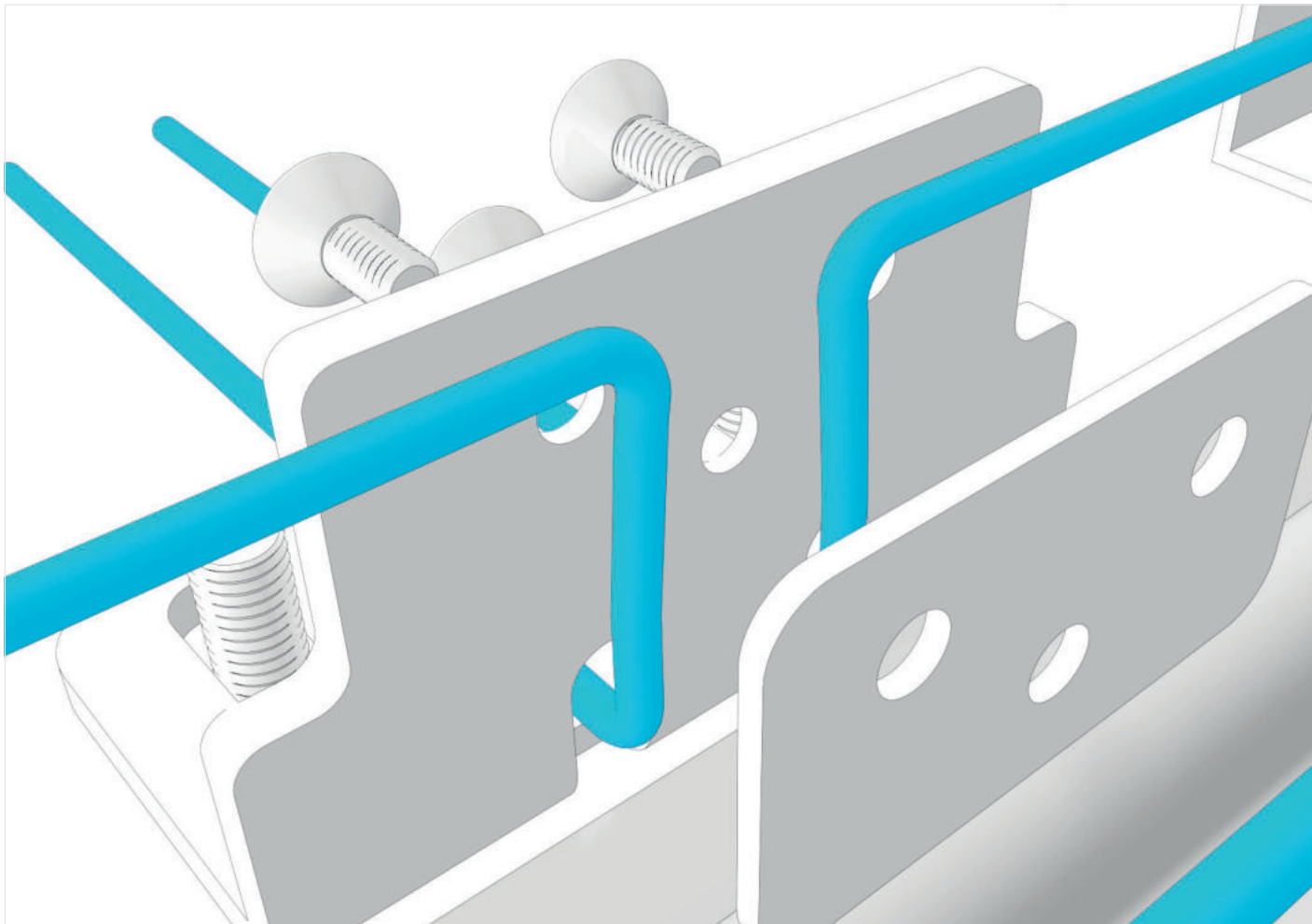

Cable tightening.

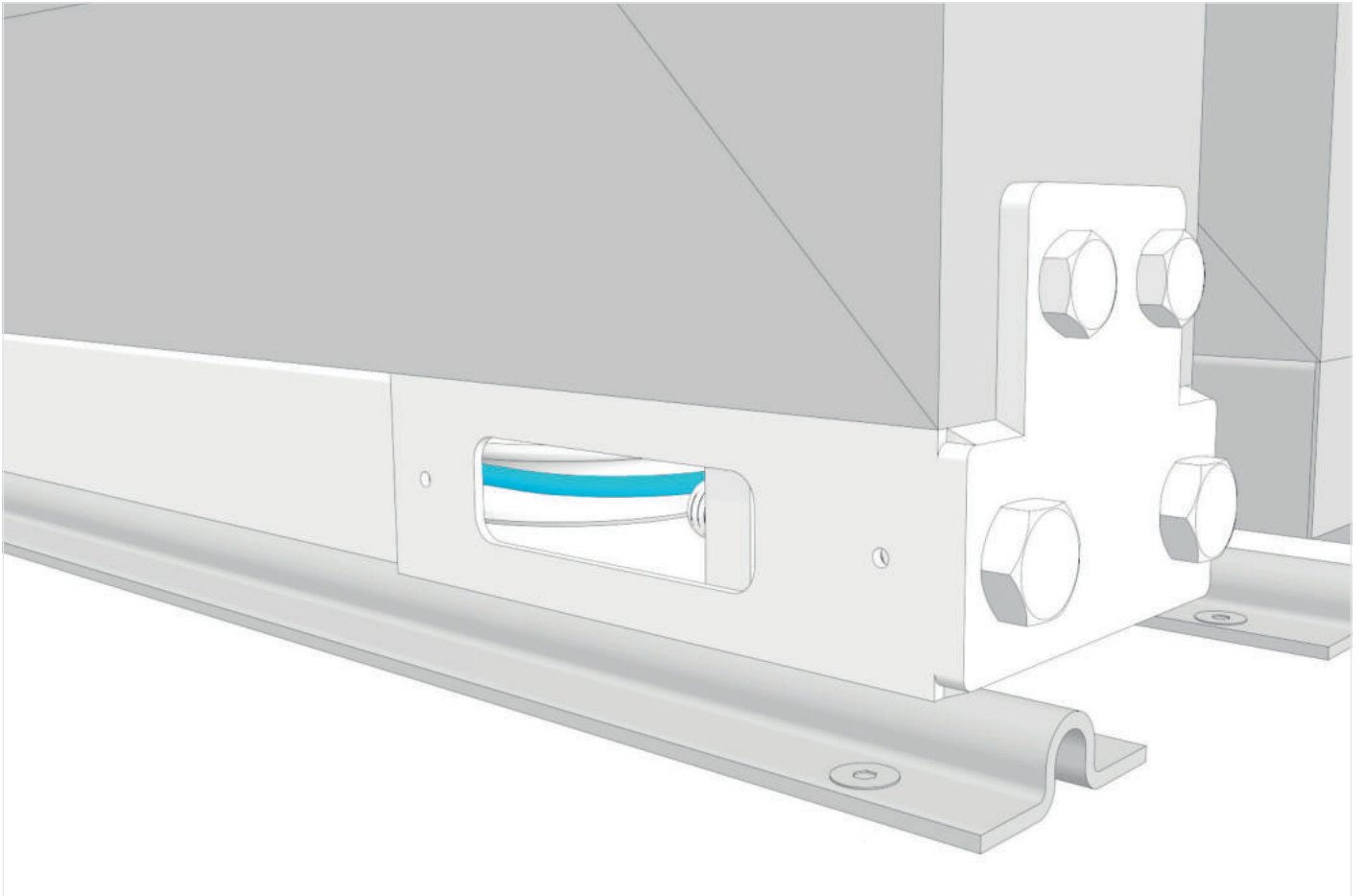

Close the sides of the pulley boxes with the supplied covers.

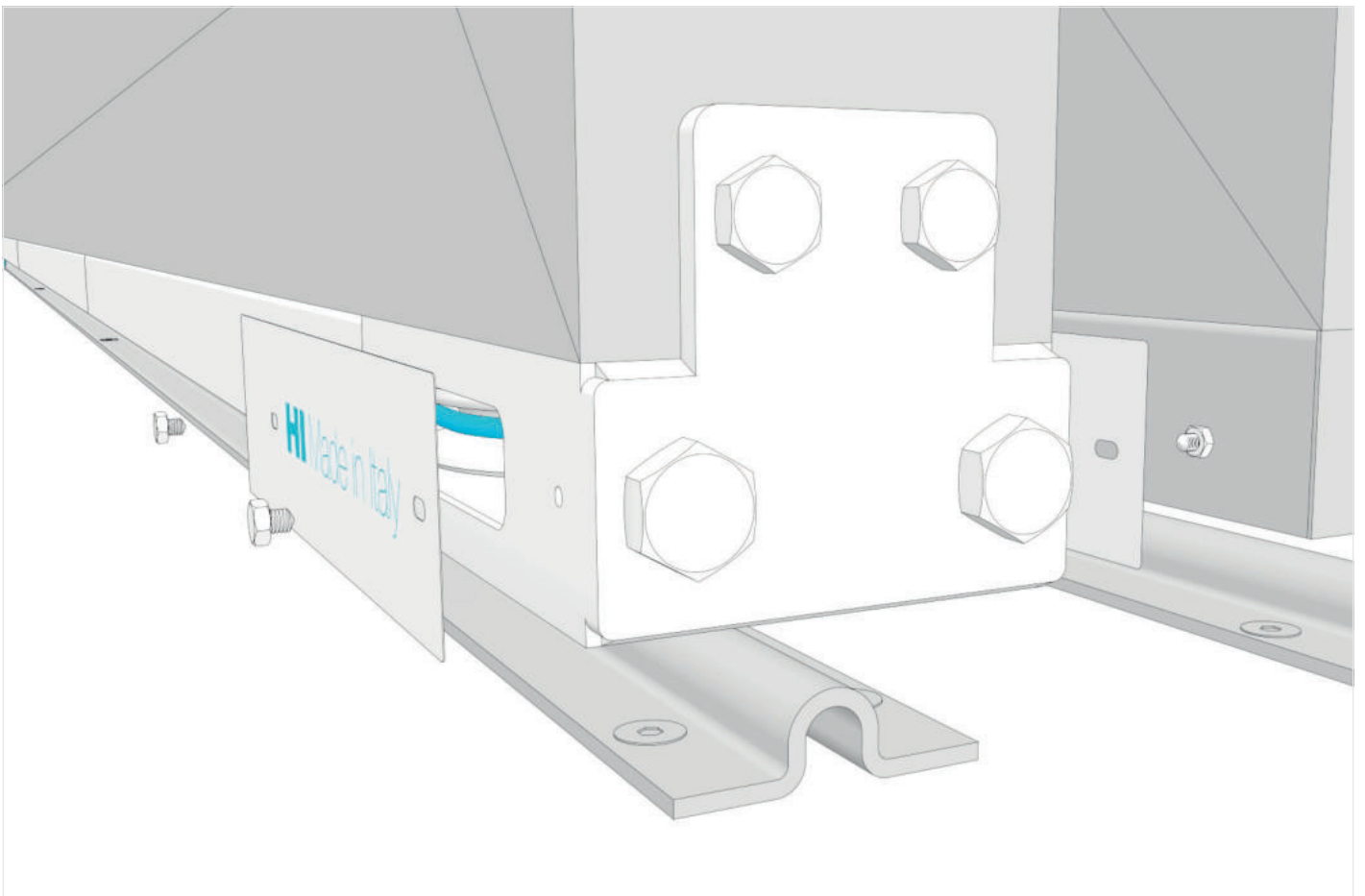

Complete the gate with your gate automation.

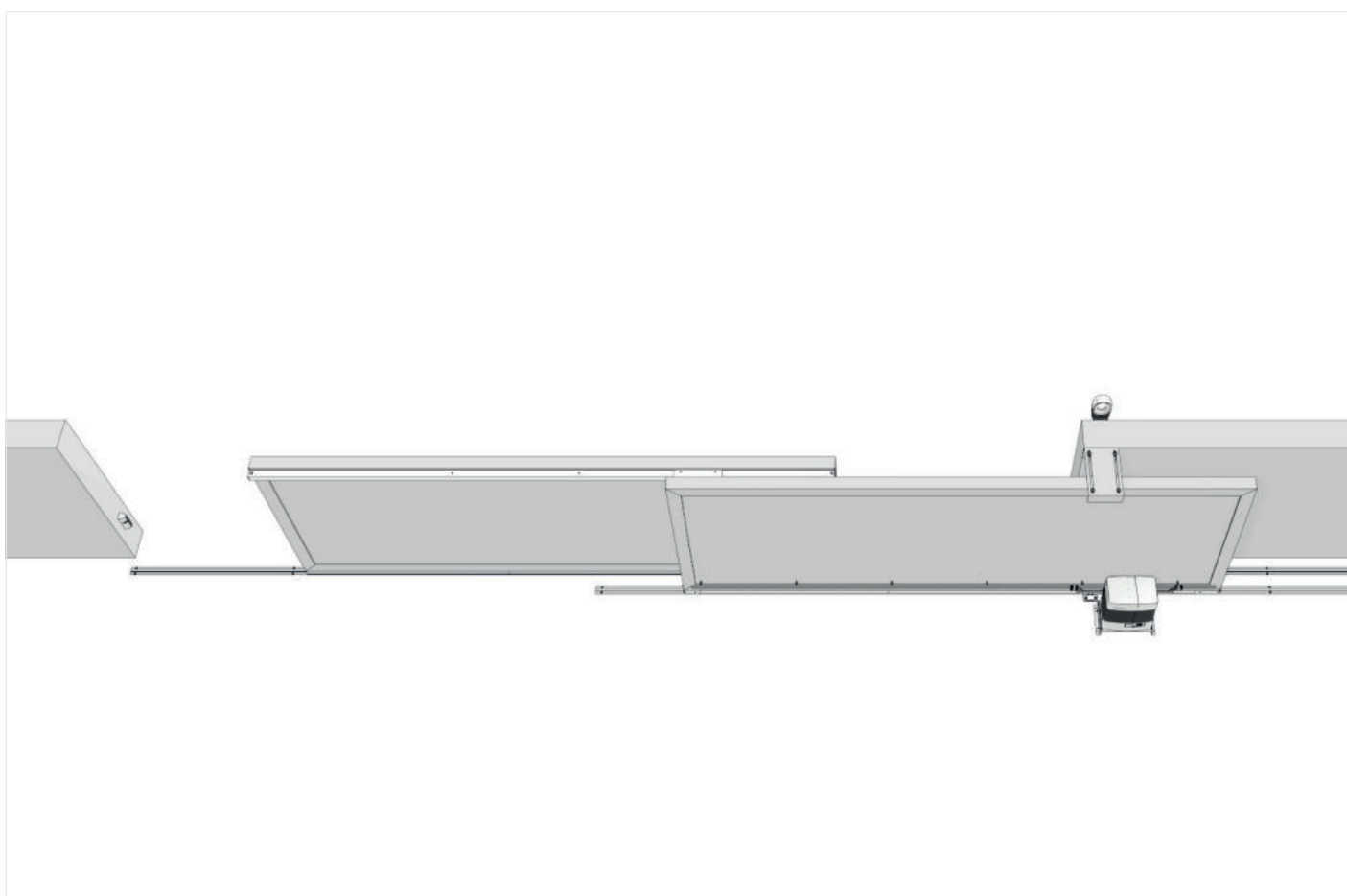
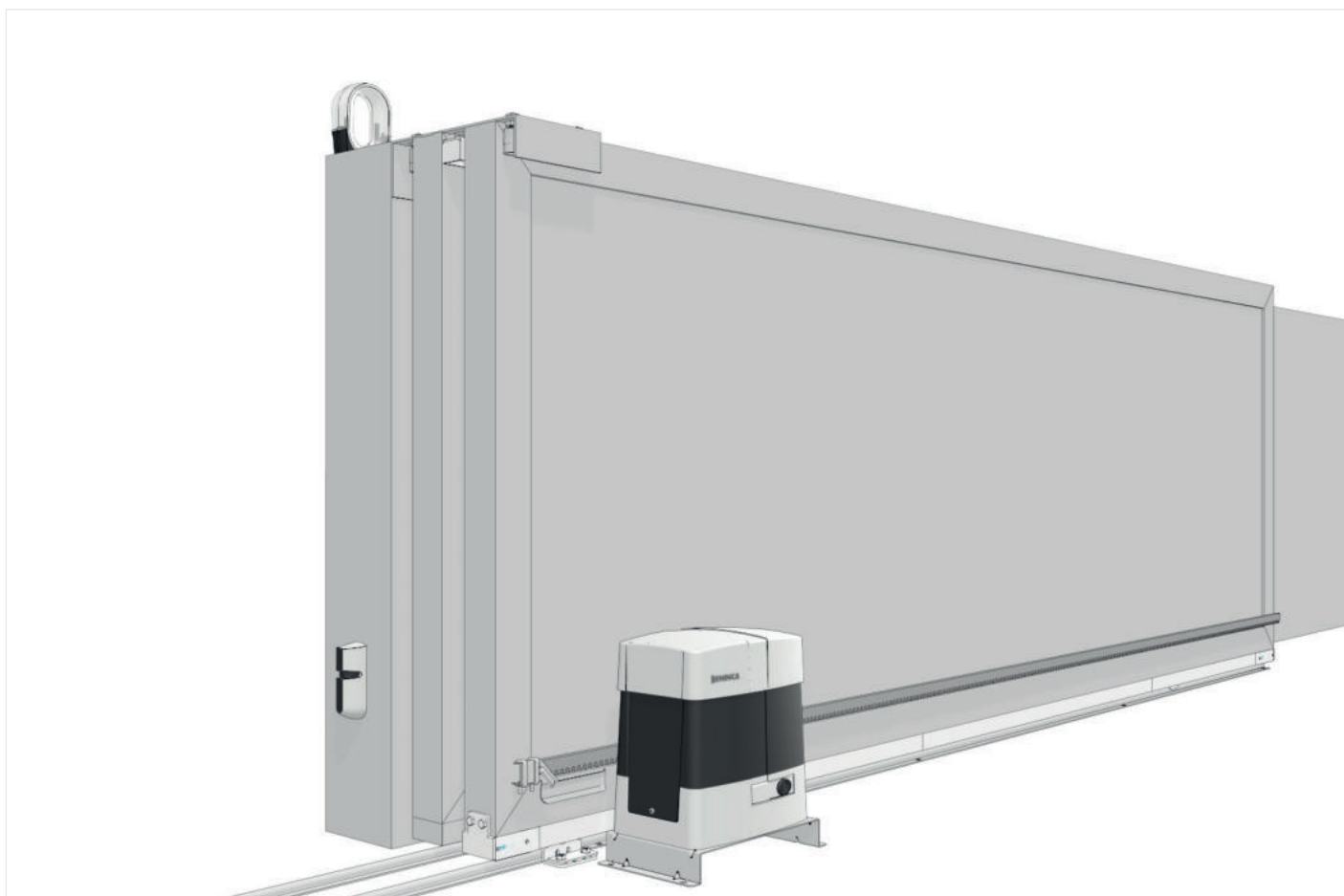

## > SIDE MOUNTING

Fix on the internal part of the first leaf, the pulley boxes and the upper guide.

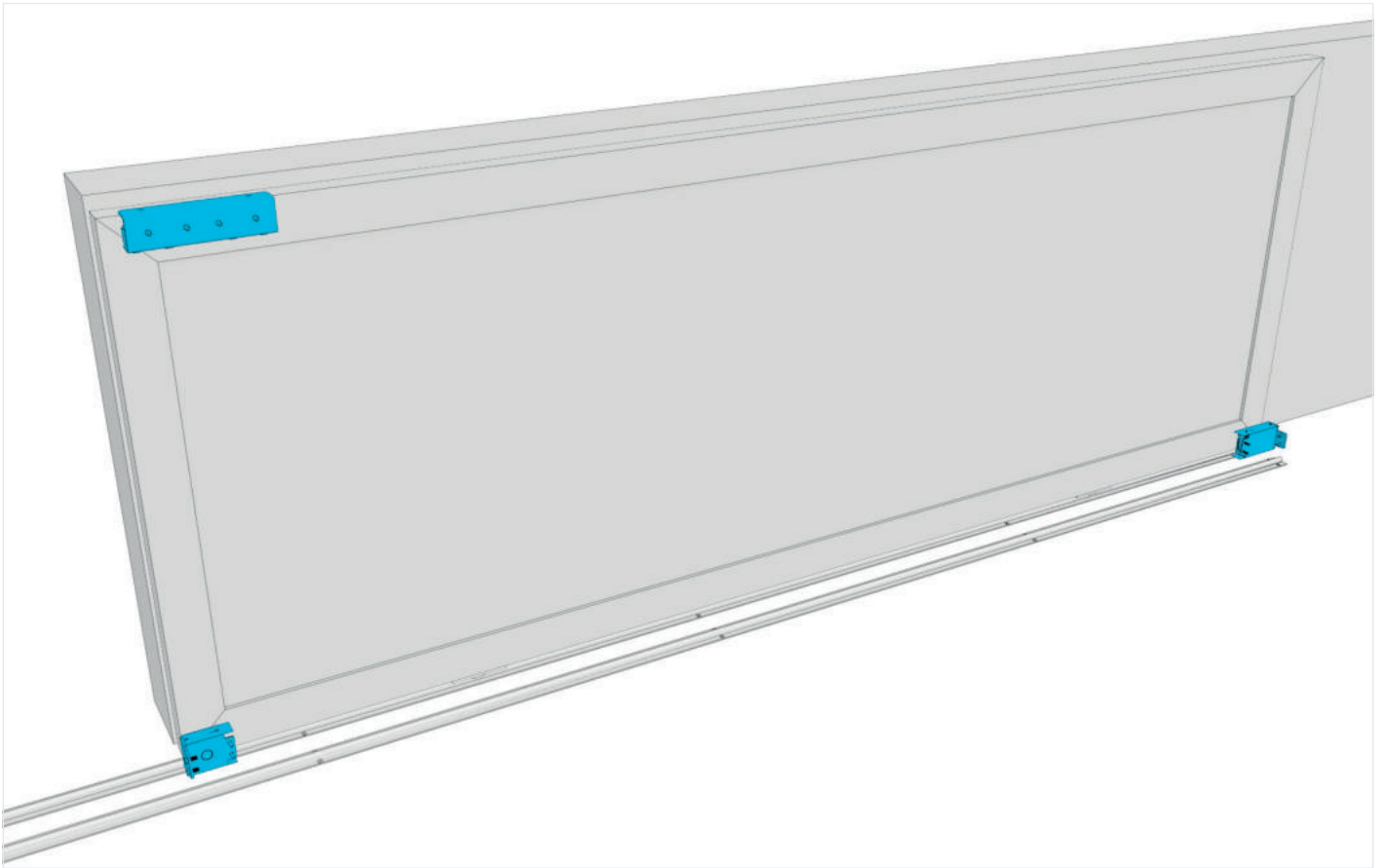

Fix the brackets on the floor and on the second leaf.

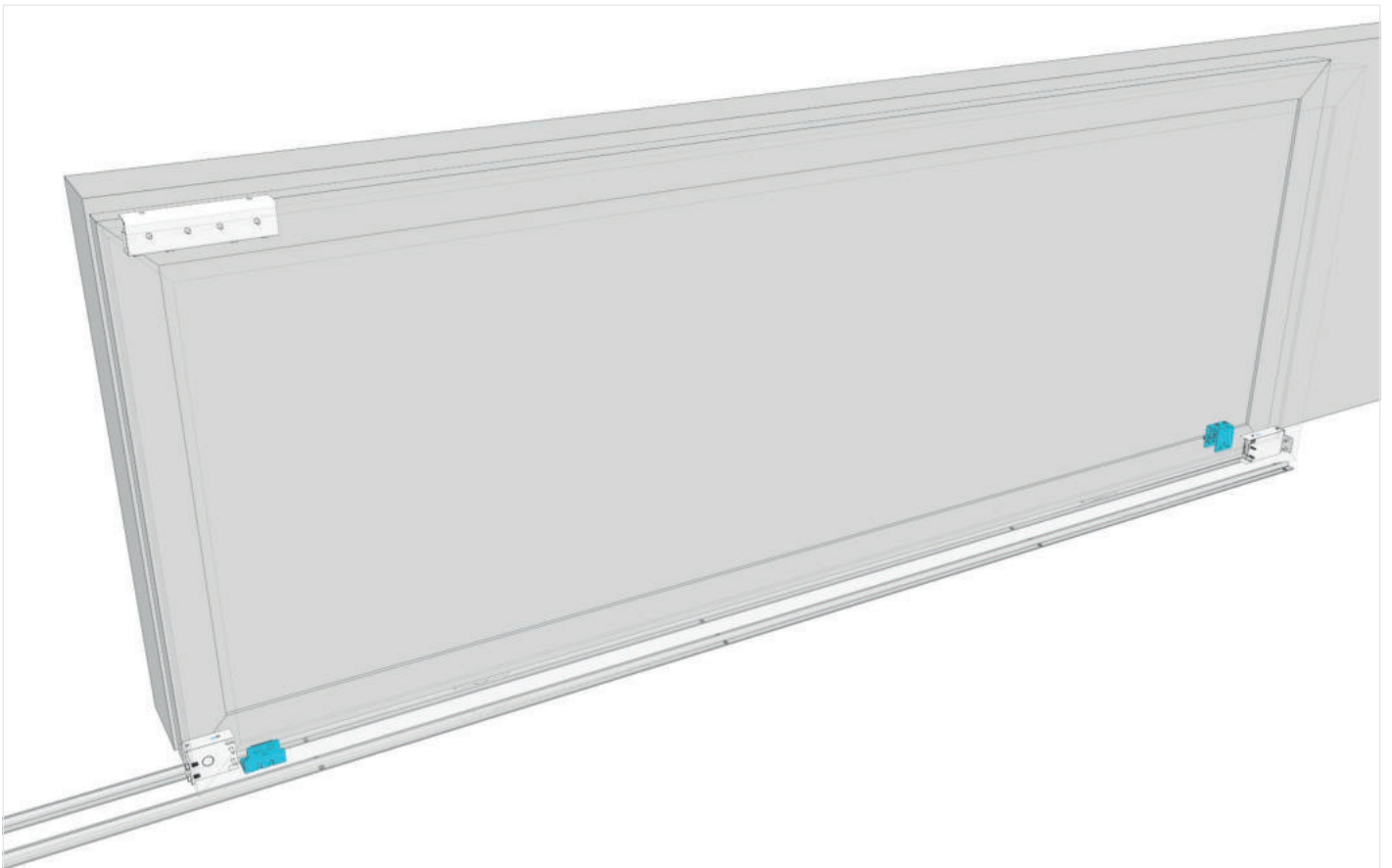

Fix the cable.

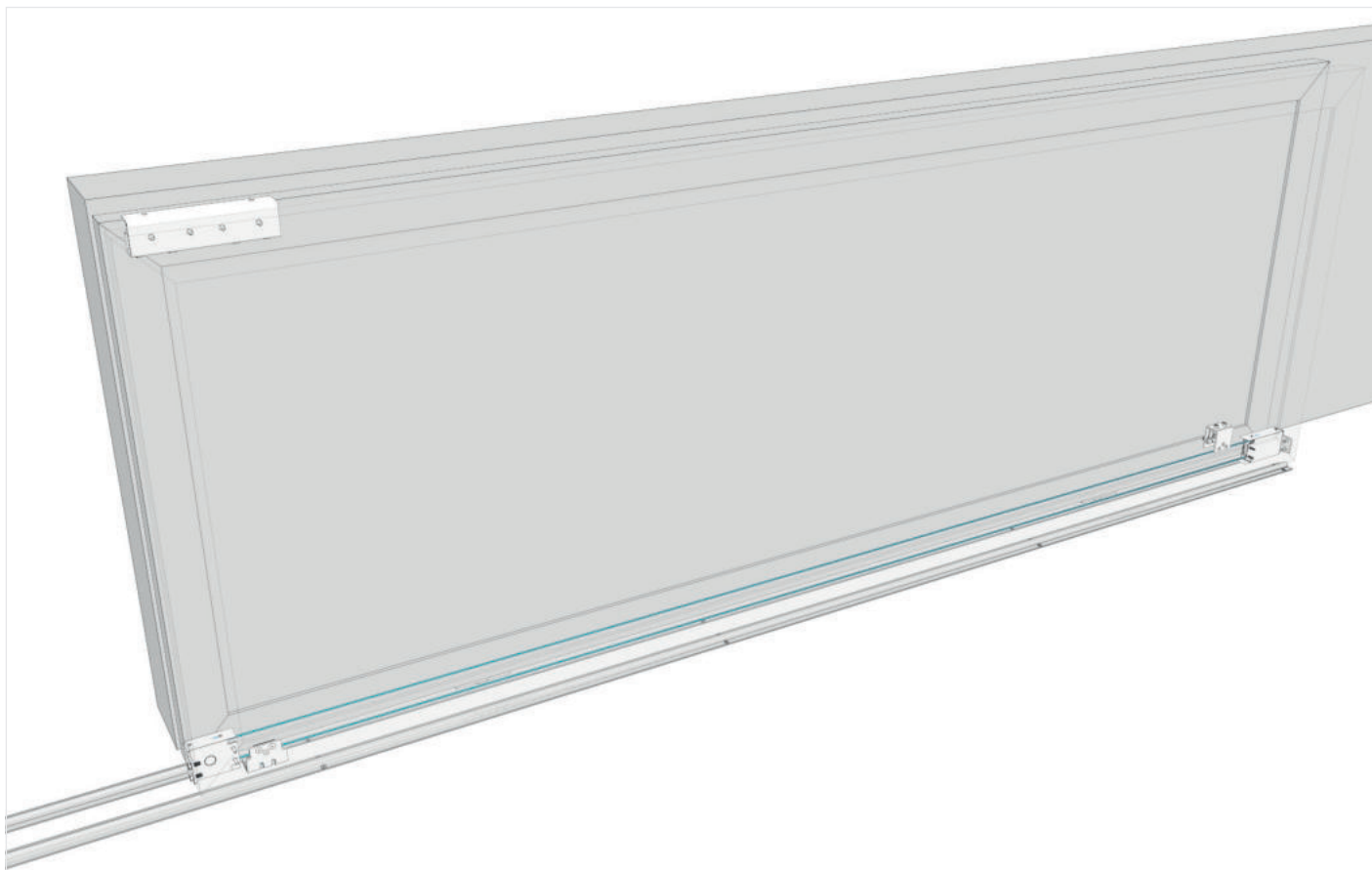

Complete the gate with your gate automation.

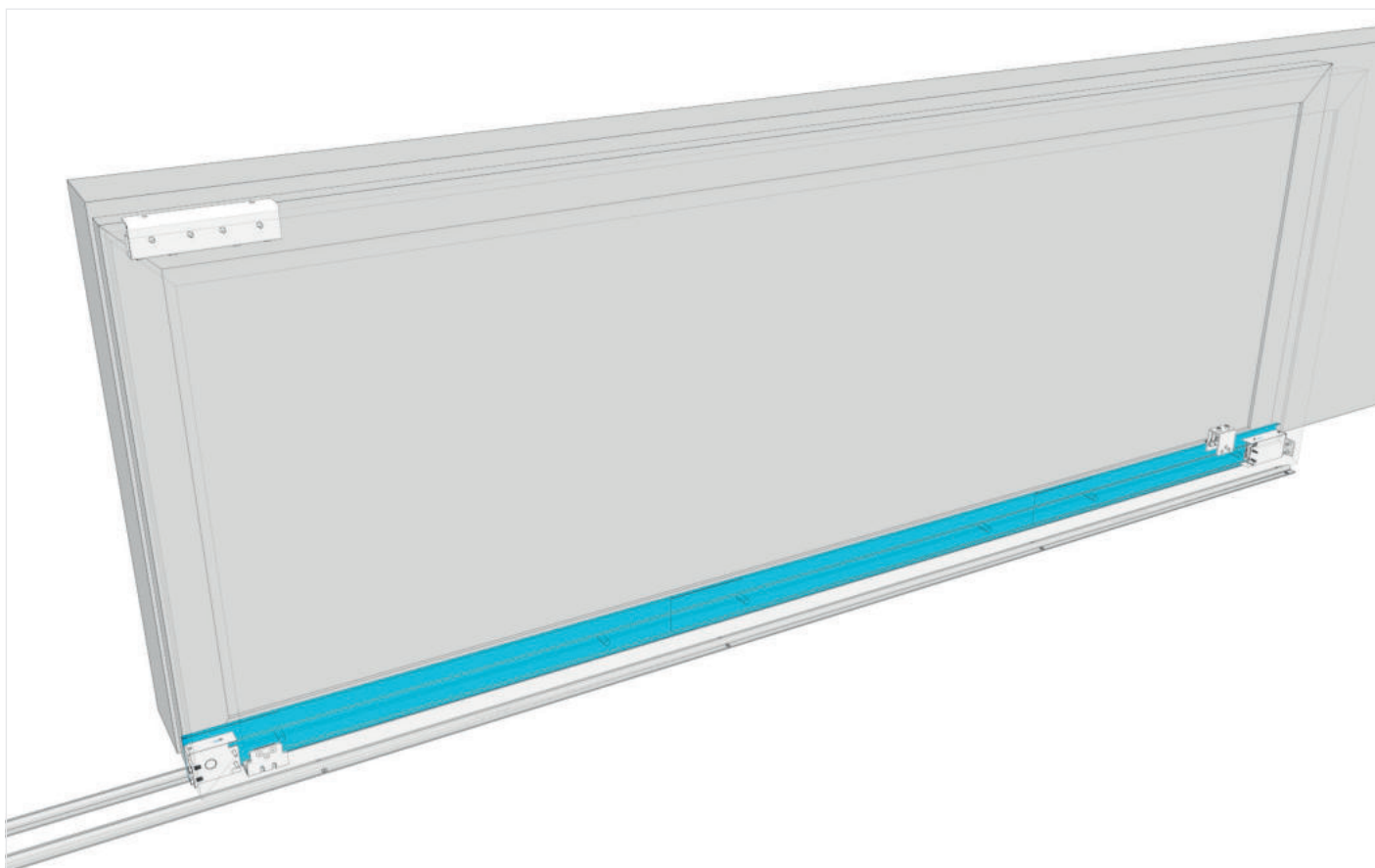



**MOTIONS**  
OPENING SOLUTIONS

---

**HI-MOTIONS Srl**

Via dell'Industria, 91  
36030 Sarcedo (VI) ITALY  
T +39 0445 367536  
F +39 0445 367520

[info@himotions.it](mailto:info@himotions.it)  
[www.himotions.it](http://www.himotions.it)